

Age Range: 1 1/2 - 4 Yrs.
 Weight Limit: 50 Lbs.
 Surfaces: Hard
 Speed: 2.5 MPH
 Colors: Blue / Purple
 Red Seat
 Black Wheels
 Intro: 5-22-97
 Suggested Retail: \$99.99
 Box Dimensions: 31" x 18.5" x 21.25"
 In Box Weight: 27 Lbs.
 Warranty: 90 Vehicle
 6 Months Battery

78410-9993 Kawasaki[®] ZX-7

Preschool Series
6-VOLT

Service Bulletins 154 & 157

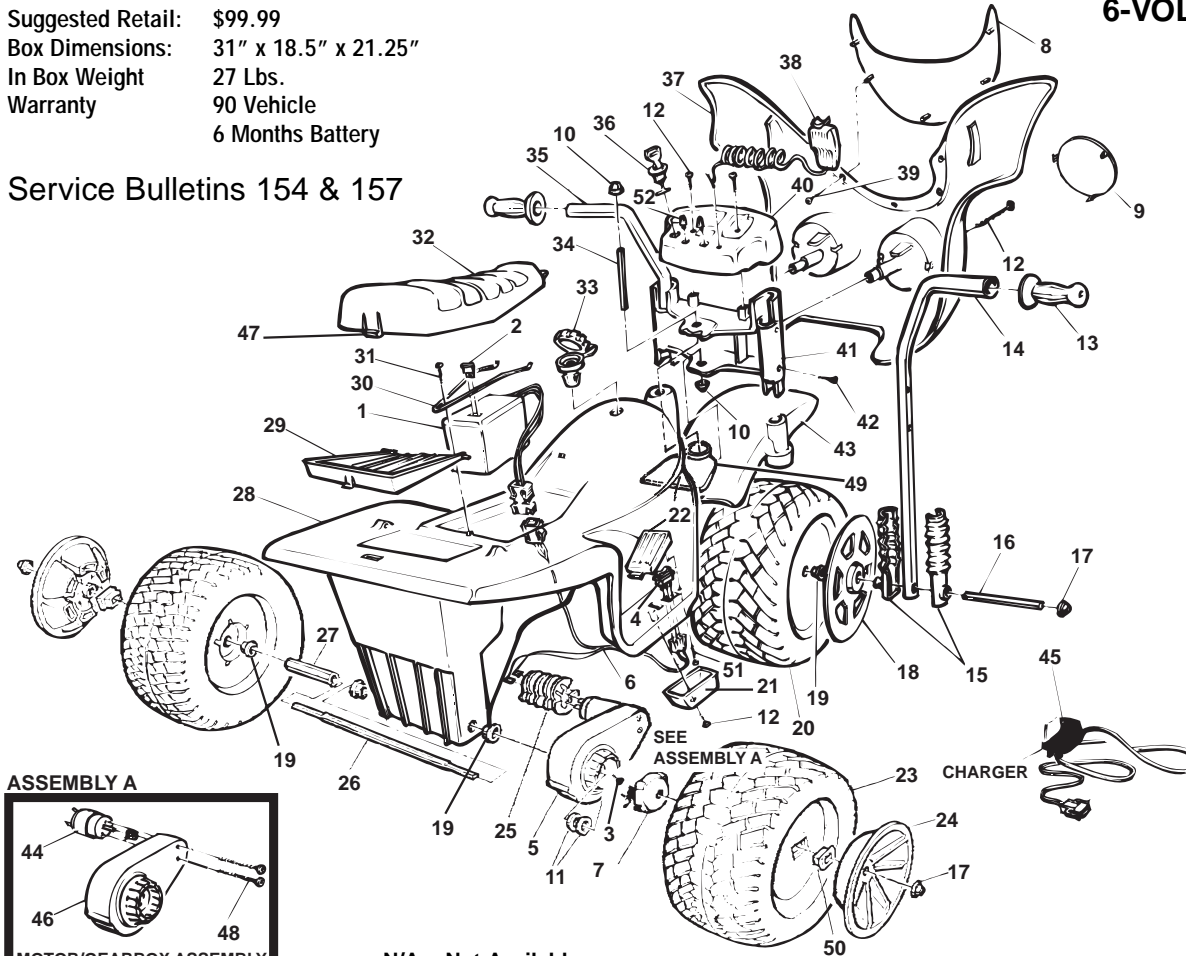

N/A = Not Available

Rev. 09/12/03

| Item No. | Description | Part No. | Qty. | Item No. | Description | Part No. | Qty. | Item No. | Description | Part No. | Qty. |
|-----------|------------------------------|-------------------|----------|-----------|------------------------|-------------------|----------|--|---------------------------|------------------|----------|
| 1 | Battery | 00801-1234 | 1 | 24 | Rear Hubcap | 78542-2589 | 2 | 47 | Lock Fastener | 78570-2239 | 1 |
| 2 | 25 amp Fuse | 0801-0151 | 1 | 25 | **Motor Cover | 76803-2489 | 1 | 48 | Motor Bolt | 0801-0198 | 2 |
| 3 | Wheel Driver Screw | 0801-0255 | 1 | 26 | Rear Axle | 74510-4549 | 1 | 49 | Flex Plate | 74510-2159 | 1 |
| 4 | *Foot Switch | 0801-0538 | 1 | 27 | Axle Spacer Tube | 74510-4449 | 1 | 50 | Rectangular Wheel Bushing | 77410-2679 | 2 |
| 5 | Motor/Gearbox Assembly | 74780-9509 | 1 | 28 | Body (N/A) | 78410-2109 | 1 | 51 | 1" Screw | 0801-0273 | 1 |
| 6 | *Wiring Harness | 78410-9799 | 1 | 29 | Trunk Lid | 78410-2329 | 1 | 52 | Radio Knobs | 74510-2149 | 2 |
| 7 | Driver | 77410-2239 | 1 | 30 | Battery Retainer | 74510-4439 | 1 | PARTS NOT SHOWN | | | |
| 8 | Windshield | 74510-2179 | 1 | 31 | 7/8" Screw | 0801-0228 | 1 | #6 - 20 x 1" Screw for | | | |
| 9 | Lens Cover Set | 74510-9159 | 1 | 32 | Seat | 78410-2309 | 1 | Swivel Bracket 0801-0254 1 | | | |
| 10 | .354 Cap Nut | 0801-0215 | 2 | 33 | Gas Cap | 74780-2049 | 1 | 11/4" Screw for Flex Plate 0801-0216 2 | | | |
| 11 | 7/16" Washer | 0801-0196 | 2 | 34 | Pivot Pin | 74510-4429 | 1 | Handlebar Plugs 74510-2169 2 | | | |
| 12 | 1-1/2" Screw | 0801-0308 | 5 | 35 | Left Handlebar | 74510-4239 | 1 | Literature Bag 78410-9029 1 | | | |
| 13 | Handgrip | 73560-2129 | 2 | 36 | Key Housing | 74550-2439 | 1 | Adhesive Harness Clip 0801-0313 1 | | | |
| 14 | Right Handlebar | 74510-4219 | 1 | 37 | Fairing | 78410-2729 | 1 | Main Decal Sheet 78410-0330 1 | | | |
| 15 | Shock Set | 78542-2089 | 1 | 38 | Microphone | 74550-9479 | 1 | Paper Decal Sheet 78410-0320 1 | | | |
| 16 | Front Axle | 74510-4519 | 1 | 39 | 3/8" Screw | 0801-0219 | 2 | Headlight Decal Sheet 78410-0300 1 | | | |
| 17 | .437 Cap Nut | 0801-0214 | 4 | 40 | Dash | 78542-2699 | 1 | Large Parts Bag 78410-9249 1 | | | |
| 18 | Front Hubcap | 78542-2579 | 2 | 41 | Swivel Bracket | 74510-2129 | 1 | Small Parts Bag 78410-9259 1 | | | |
| 19 | Wheel Spacer | 74550-2689 | 5 | 42 | 3/4" Screw | 0801-0223 | 4 | Use & Care Manual 78410-0920 1 | | | |
| 20 | Front Wheel | 74510-2459 | 1 | 43 | Fender | 78410-2249 | 1 | | | | |
| 21 | Footboard Cover | 77410-2159 | 1 | 44 | Motor w/ Pinion | 74590-9539 | 1 | | | | |
| 22 | Foot Pedal w/Spr Clip | 78560-9159 | 1 | 45 | Charger | 00801-0975 | 1 | | | | |
| 23 | Rear Wheel | 74510-2469 | 2 | 46 | 3A Gearbox | 74580-9269 | 1 | | | | |

*For Footswitch, See **Both** Service Bulletins 154 & 157
 **When depleted, use new motor cover 74750-2539
 (effective 5-24-98)

Bold and Underlined parts are to be purchased and installed by Service Centers only. These items may not be sold directly to consumers by Service Centers or Fisher-Price.

