

COFFEE MACHINE

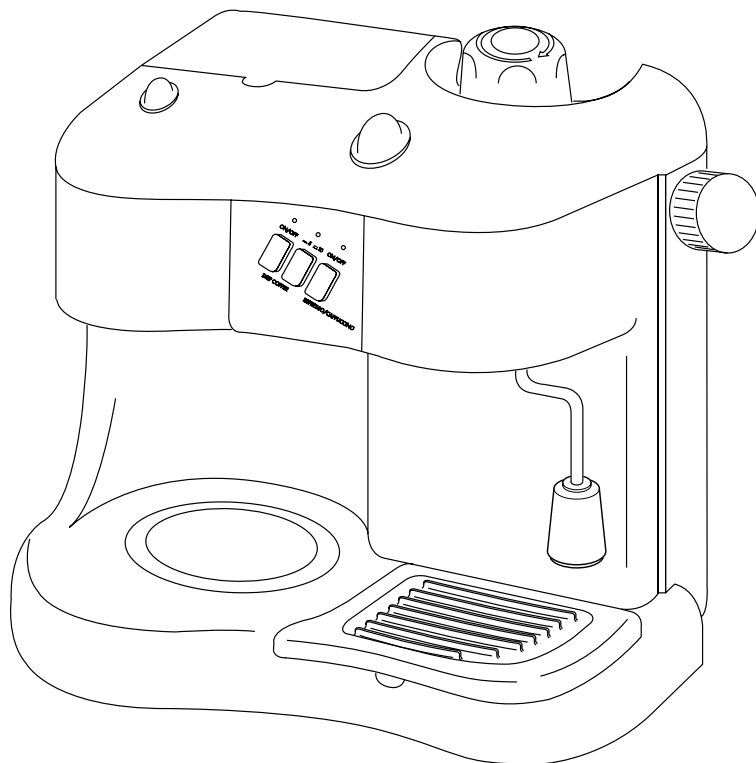

Owner's instructions

BCO110

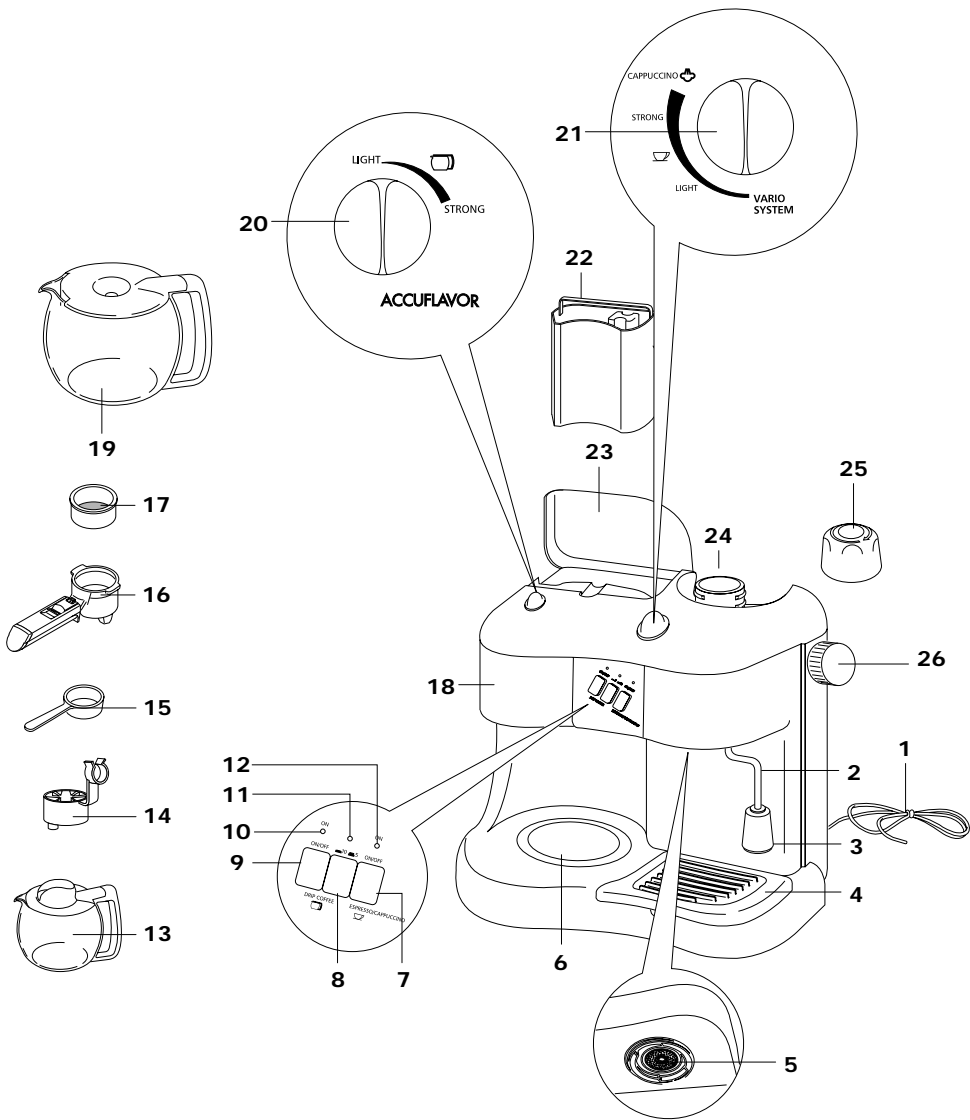

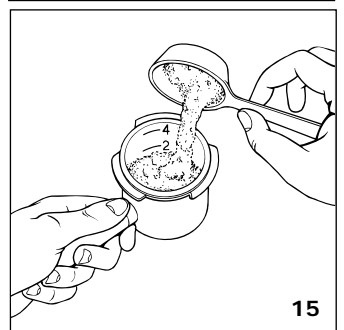
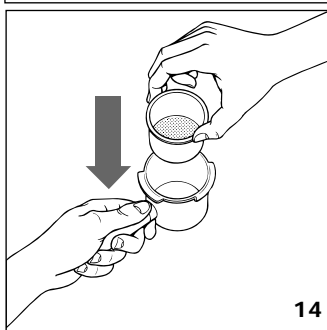
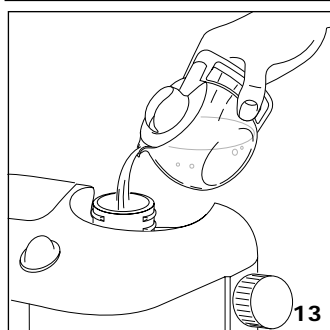
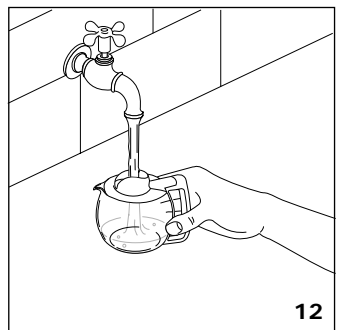
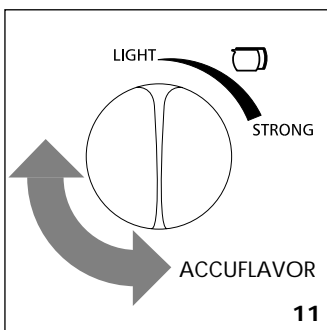
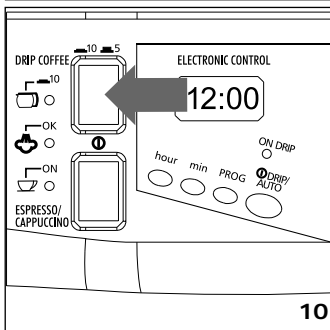
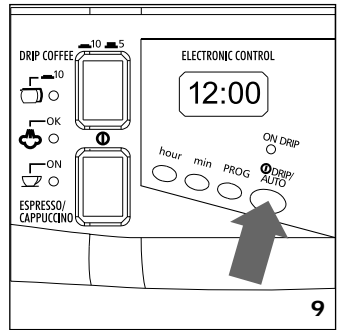
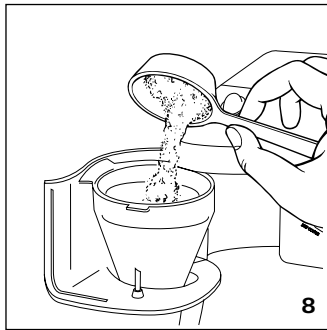
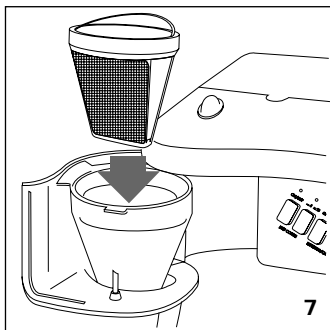
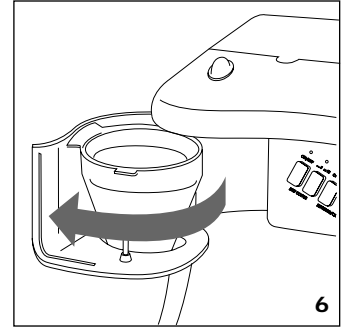
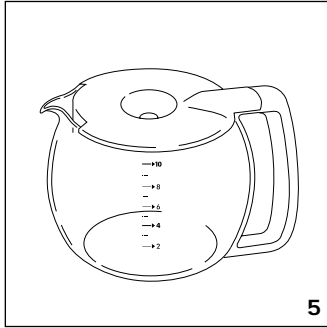
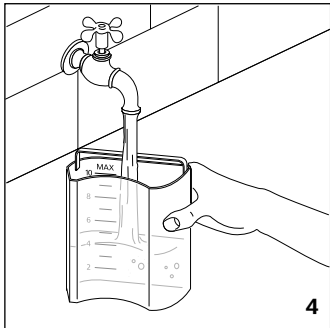
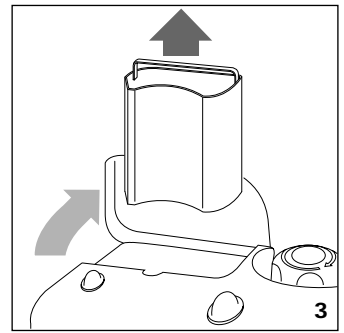
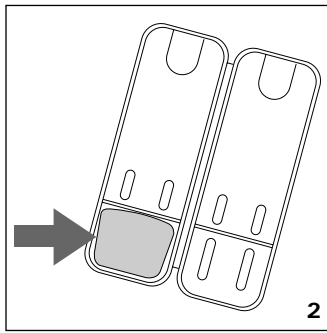
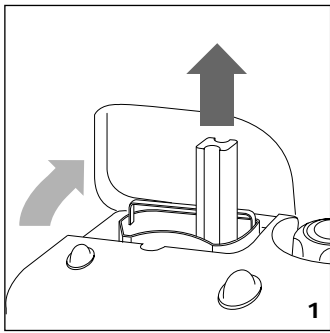

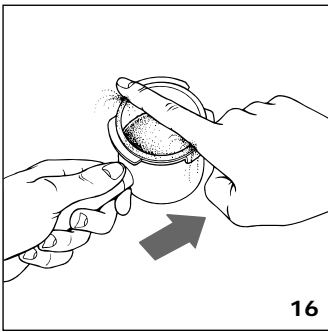

16

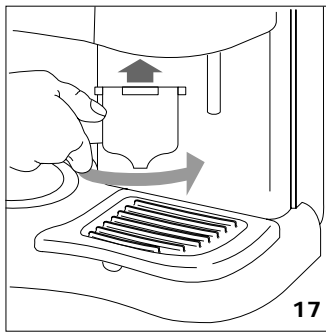

17

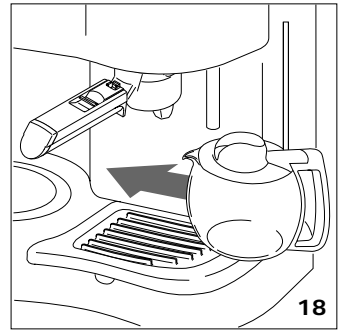

18

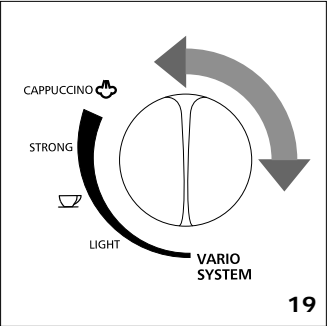

19

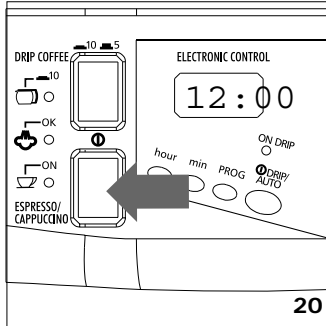

20

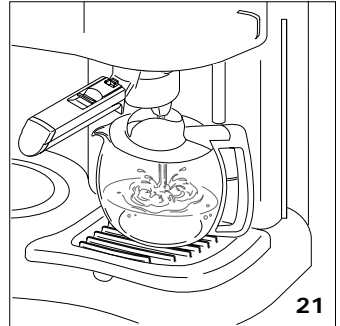

21

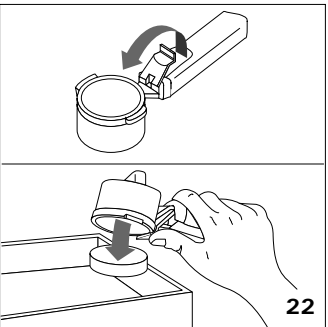

22

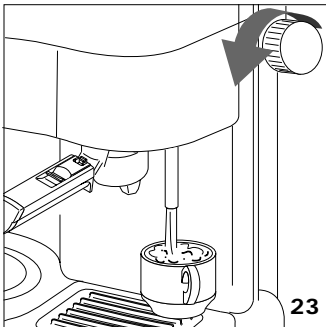

23

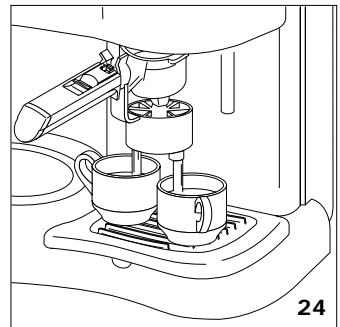

24

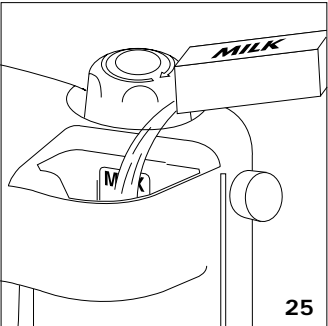

25

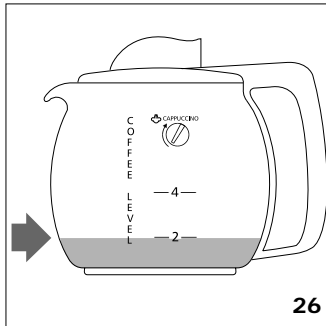

26

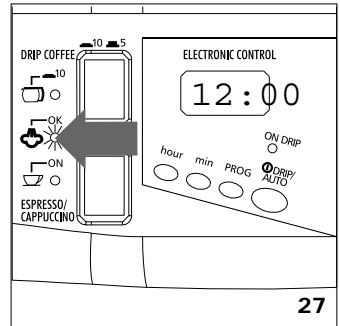

27

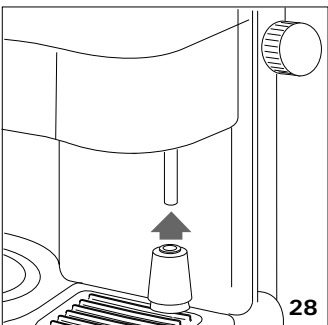

28

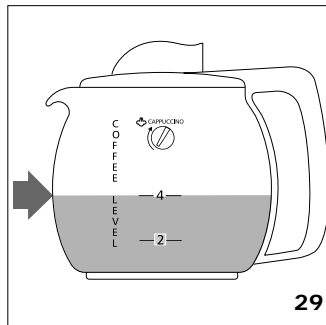

29

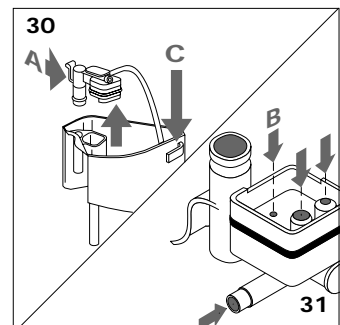

30

31

IMPORTANT SAFEGUARDS



When using electrical appliances, basic safety precautions should always be followed, including the following:

- Read all instructions.
- Do not touch hot surfaces. Use handles and knobs.
- To protect against fire, electrical shock and personal injury, do not immerse cord, plug or appliance in water or other liquid.
- Close supervision is necessary when any appliance is used by or near children.
- Unplug from the outlet when not in use and before cleaning. Allow to cool before fitting or taking off parts, and before cleaning the appliance.
- Do not operate with a damaged cord or plug, or after the appliance malfunctions, or has been damaged in any manner. Return the appliance to the nearest authorized service facility for examination, repair or adjustment.
- The use of accessory attachments or spare parts not recommended by the appliance manufacturer may result in fire, electrical shock or personal injury.
- Do not use outdoors.
- Do not let the cord hang over the edge of the table or counter, or touch hot surfaces.
- Do not place on or near a hot gas or electrical burner, or in a heated oven.
- Always attach plug to appliance first, then plug cord into the wall outlet. To disconnect, turn any control to "off", then remove plug from wall outlet.
- Do not use the appliance for other than the intended use.
- DO NOT unscrew or remove boiler cap while the machine is in operation. Wait until brewing cycle is completed and all water and steam has been used up.
- Appliances with Glass Containers:
 - A. The container is designed for use with this appliance. It must never be used on a range top.
 - B. Do not set a hot container on a wet or cold surface.
 - C. Do not use a cracked container or a container having a loose or weakened handle.
 - D. Do not clean container with cleansers, steel wool pads, or other abrasive material.

SAVE THESE INSTRUCTIONS

SHORT CORD INSTRUCTIONS



- A short power cord is provided to reduce risks resulting from becoming entangled in or tripping over a longer cord.
- Longer, detachable power supply cords or extension cords are available and may be used if care is exercised in their use.
- If an extension cord is used, the marked electrical rating should be at least as great as the electrical rating of the appliance. If the appliance is provided with 3-wire, grounding type cord, the extension should be a GROUNDING TYPE 3 - WIRE CORD. The longer cord should be arranged so that it will not drape over the counter-top or table top where it can be pulled on by children or tripped over.
- Your product is equipped with a polarized alternating current line plug (a plug having one blade wider than the other). This plug will fit into the power outlet only one way. This is a safety feature. If you are unable to insert the plug fully into the outlet, try reversing the plug. If the plug should still fail to fit, contact your electrician to replace your obsolete outlet. Do not defeat the safety purpose of the polarized plug.

ENGLISH

Please read this instructions manual carefully before installing and using the appliance. Only by following these directions will you be able to obtain the best results from the appliance and in complete safety.

DESCRIPTION OF THE APPLIANCE

The following terms are used throughout the instructions manual.

1. Power supply cable
2. Drip collection pan
3. Anti spray nozzle
4. Hot water drip spout
5. Hot plate
6. Display
7. Coffee ON DRIP pilot light
8. Coffee DRIP/AUTO button
9. PROG button
10. 'Min' button
11. 'Hour' button
12. ON/OFF switch espresso coffee/cappuccino
13. ON warning light espresso coffee/cappuccino
14. Steam ready warning light
15.  10 cups warning light for drip coffee
16.  10  5 cups switch for coffee drip
17. Small coffee pot for espresso coffee/cappuccino
18. Two cup attachment for espresso coffee
19. Measuring spoon
20. Filter holder for drip coffee
21. Filter holder for espresso coffee
22. Permanent filter (if supplied)
23. Filter for espresso coffee
24. Drip coffee pot
25. Drip coffee aroma selector switch
26. Lid for the water tank
27. Removable water tank
28. Anti-chlorine water filter holder (if supplied)
29. Anti-chlorine water filter (if supplied)
30. "Vario system" selector switch
31. Lid for milk tank
32. Milk frother
33. Milk tank
34. Hot water heater plug
35. Hot water heater for steam
36. Steam release knob

INSTALLATION

- Place the appliance on a flat work surface away from water sources such as taps or sinks.
- Check that the voltage of the electrical power line corresponds to the voltage indicated on the appliance label.
- Never install the machine in an environment which can reach a temperature of less than or equal to 0°C (if the water inside the machine freezes, the machine might be damaged):

ANTI-CHLORINE FILTER (IF SUPPLIED)

The anti-chlorine filter eliminates the taste of chlorine in the water. For installation, proceed as follows:

- Remove the anti-chlorine filter from the plastic bag and rinse it thoroughly under running tap water.
- Raise the coffee lid, remove the container from its housing by pulling it up (Fig. 1).
- Open the container by pressing on the opposite areas, marked with the writing "PUSH" and place the filter into its housing carefully as illustrated in fig. 2.
- Close the container and reinsert it into the housing by pressing down gently.
- After 80 cycles, or in any case after six months of use, the anti-chlorine filter must be replaced.

HOW TO SET THE CLOCK

When the coffee maker is connected for the first time to the electrical mains, the figures 12:00 appear on the display, blinking.

In order to set the time, proceed as follows:

1. Set the hour by repeatedly pressing the HOUR button. Remember to choose AM or PM, as appropriate.
2. Set the minutes by repeatedly pressing the MIN button.

The above operations may be speeded up by keeping the buttons pressed.

NOTE: The time entered will not be stored in memory in the event of a temporary blackout of electrical energy.

HOW TO SET THE TIMER

Make sure that the clock has been set correctly.

To set the timer for delayed activation (to turn on the coffee maker at the time that you want the coffee to be made), proceed as follows:

1. To set the hour, press the PROG button and simultaneously repeatedly press the HOUR button.
2. To set the minutes, press the PROG button and simultaneously repeatedly press the MIN button.

Note: the coffee maker will automatically begin making coffee at the set hour, but will not turn on the hot water generator for espresso coffee.

HOW TO PREPARE THE COFFEE FILTER

- Raise the lid and remove the water tank (fig. 3).
- Fill the tank with cold, clean water, up to the level indicated on the tank corresponding to the number of cups of coffee that are desired (fig. 4).
- Reinsert the tank into the machine by pressing it slightly. If desired, the tank can be left in its place and to fill it, the drip coffee pot can be used which also has the level indicators on it (fig. 5).
- Open the filter holder by turning it towards the left (fig. 6).
- Place the permanent filter into the filter holder (fig. 7).
- Put the ground coffee into the filter by using the measuring spoon included with the machine and level off the grounds uniformly (fig. 8). As a general rule, use one level measuring spoonful of coffee (about 7 grams) for each cup of coffee (for example, use 10 measures to make 10 cups of coffee). In any case, the quantity of ground coffee to use can vary according to the strength desired and personal taste. Use high quality ground coffee, with a medium grind and the kind packaged especially for drip coffee makers.
- Close the filter holder and place the pot, with its lid inserted, onto the hot plate.
- Select the aroma desired as indicated in the paragraph "How to select the aroma".

- If you wish to turn the coffee maker on immediately, press the ① DRIP/AUTO button twice (fig. 9) and the ① ON DRIP pilot light will come on. Alternatively, if you wish the appliance to turn on after a certain delay, press the DRIP/AUTO button just once; the word PROG will appear in the top left-hand corner of the display and the coffee maker will automatically turn on at the time set (as described in the "HOW TO SET THE TIMER" section).
- If more than five cups of coffee are desired, press the switch (— 10 — 5) (fig. 10) and the 5/10 cup warning light will light up. If, on the other hand, five or fewer cups of coffee are desired, the switch should not be pressed. In this way, the hot water will flow more slowly through the ground coffee and a more flavorful beverage will be obtained.
- The brewed coffee will begin to drip out after a few seconds. **It is completely normal that during the percolation of the coffee, some steam may escape from the machine.**
- If the ① DRIP/AUTO button (fig. 9) is left pressed after percolation, and the container is standing on the heating plate, the coffee will be kept at the ideal temperature.

HOW TO SELECT THE AROMA OF THE FILTER COFFEE

With the ACCUFLAVOR, it is possible to select the aroma of the filter coffee depending on personal taste. By turning the aroma regulation knob of the coffee filter (fig. 11), the coffee machine can be programmed for a strong aftertaste (STRONG position) or a lighter flavor (LIGHT position). The ACCUFLAVOR feature changes the aftertaste of the coffee, more or less strong, while the true taste of the coffee remains unchanged.

HOW TO PREPARE ESPRESSO COFFEE

1. Unscrew the plug of the hot water heater tank by turning it in a counter-clockwise direction.
2. Fill the small container for espresso coffee with the quantity of water indicated in the table at the end of the text and in accordance with the number of cups of espresso that you wish to make (fig. 12).
3. Pour the water into the hot water heater tank (fig. 13).

4. Replace the plug in the hot water heater tank by turning firmly in a clockwise direction.
5. Insert the filter for espresso coffee into the filter holder (fig. 14).
6. Fill the filter with the ground coffee, respecting the dosages indicated in the chart at the end of this text and distribute it uniformly in the filter (fig. 15). It is important to use the highest quality coffee and having a medium grind in order to avoid the obstruction of the filter during the brewing. Remove any excess coffee from around the edges of the filter (fig. 16).
7. To attach the filter holder to the appliance, position it under the hot water drip spout with the handle towards the left, see fig. 17. Push upwards, and at the same time, turn the handle towards the right. **Always turn right to the end.**
8. Place the coffee pot for espresso coffee under the filter holder so that the spout where the coffee exits the filter is inside of the opening found on the lid of the coffee pot (fig. 18).
9. Position the "Vario System" selector according to the type of espresso coffee desired: "LIGHT" for a lighter coffee and "STRONG" for a stronger tasting brew (fig. 19).
10. Make sure that the steam release knob is closed.
11. Push the  ON/OFF switch for espresso/cappuccino (fig. 20). The ON/OFF warning light for espresso/cappuccino will turn on.
12. After approximately two minutes, the espresso coffee will begin to flow out (fig. 21).
ATTENTION: to avoid spraying, never detach the filter holder while the machine in brewing coffee.
13. When the coffee no longer flows out from the filter holder, push the ON/OFF switch for espresso/cappuccino to turn off the hot water heater (fig. 20). Pour the coffee into the cups.
14. To eliminate the used coffee in the filter, detach the filter holder, keeping the filter locked in place with the special lever incorporated in the handle and remove the coffee by turning the filter holder upside down and striking gently (fig. 22).

ATTENTION: Before removing the filter holder, it is important to eliminate all of the residual steam

from the inside of the hot water heater to avoid puffs of steam. Allow it to blow out completely by rotating the steam release knob (fig. 23).

NOTE: For safety reasons, when the hot water heater is hot, it is not possible to remove its plug as it will spin without opening. If for any reason it is necessary to remove it, it is important to always release the steam in the hot water tank by acting on the steam release knob as described in the previous point.

ATTENTION: The first time that coffee is prepared, it is necessary to wash all of the accessories and the internal circuits of the machine as follows:

- For the coffee machine filter: make at least two pots of coffee without using the ground coffee in the filter (following the instructions in the paragraph How to prepare the coffee filter);
- For the espresso coffee filter: make at least four cups of espresso coffee without using ground coffee in the filter (following the instructions in the paragraph How to prepare the espresso coffee filter);

HOW TO USE THE TWO CUP ATTACHMENT

The attachment must be used every time that it is desired that the coffee drips directly into the cups. To mount the attachment, it is sufficient to attach it to the lower part of the filter holder (fig. 24).

HOW TO PREPARE CAPPUCCINO

- Prepare the espresso coffee as described in the paragraph "How to prepare espresso coffee" from points 1 through 12; using however, the quantity of water necessary to obtain 2 cappuccinos as indicated in the chart at the end of this text. Note that the quantity of water required for making cappuccinos is greater than the amount necessary for making espresso coffee: the extra water is used for the production of steam for frothing the milk.
- In the meantime, pour the milk, **not boiled and not hot**, into the milk tank (fig. 25). With the tank filled to the MAX line, there will be enough milk to make 2 or 3 cappuccinos. Never fill beyond the MAX line otherwise once the cappuccino has been made, the milk may

continue to drip out of the tube.

- Brew the coffee into the small espresso coffee pot. When the darker colored coffee (which lies under the lighter coffee colored froth) reaches the level 2 on the "COFFEE LEVEL" side of the small espresso pot (fig. 26), place the Vario System selector to the "cappuccino" mode (fig. 19). Careful attention must be paid to this operation: in fact, if the coffee should surpass the level 2, there will be no water left in the tank to make the steam for frothing the milk.
- Pour the coffee into 2 sufficiently large cups.
- Place the cup containing the coffee under the tube of the milk tank, making sure that the milk tank has been attached firmly, then turn the steam release knob in a counter-clockwise direction. The frothed milk will begin to exit from the tube of the milk tank (fig. 23). Before beginning this operation, always wait for the "OK" light (fig. 27) to turn on which indicates that the ideal temperature has been reached for frothing the milk. To keep the milk from spraying it is necessary to slide on the anti-spray nozzle (fig. 28) onto the tube of the milk tank. This is also useful when the cups used for the cappuccino are quite small.
- Fill the cup with the desired quantity of frothed milk. **To ensure that the milk froths correctly, always wait for the "OK" warning light to turn on before frothing milk between one cappuccino and the other.**
- **ATTENTION: Once the frothing of milk for the last cappuccino has finished, before closing the steam handle always wait until all the steam has come out from the milk tank tube; in this way you avoid the milk going sour in the internal tubes of the frother.**
- **Press the $\text{\textcircled{O}}$ ON/OFF switch for espresso/cappuccino to turn off the appliance.**
- In order to make 4 cappuccinos, it is necessary to repeat the previous operations, paying attention to the quantity of ground coffee and water, indicated in the chart at the end of the text. Furthermore, before positioning the Vario System selector to the Cappuccino position, brew enough coffee into the coffee pot to reach the level 4 on the "COFFEE LEVEL" side as indicated in figure 29.

- To make the perfect cappuccino, we recommend the use of the following proportions: 1/3 coffee, 1/3 plain hot milk, and 1/3 frothed milk.

CLEANING AND MAINTENANCE

- Before beginning any cleaning or maintenance operation, turn the machine off, remove the plug from the electrical power source and let the machine cool down.

CLEANING THE MILK FROTHER

The cleaning operations for the milk frother must be done after each use. Proceed as follows:

- Remove the milk tank by pressing the 'C' lever (fig. 30) and simultaneously pulling upwards; wash it with warm water.
- Remove the red milk frothing instrument by pressing down on lever (A) and at the same time, pulling upwards (fig. 30). Remove the rubber mixer, rinse it and clean it thoroughly with hot water, with special attention paid to the holes illustrated in figure 31 (clean them with the use of a needle).

Make sure that the hole marked with the arrow B (fig. 31) has not been clogged (clean it with the use of a needle).
- Once clean, all of the pieces must be reassembled in the correct order. In particular, make sure that the rubber mixer has been inserted properly all the way down and that the milk tank and the red milk frother have been inserted all the way until a click is heard.

If this cleaning need is not done after every use, the milk frothing operation may not come out well or it may happen that either the milk is not drawn up properly or that the milk drips from the milk tank tube.

OTHER CLEANING PROCEDURES

- To clean the machine, do not use solvents or abrasive detergents. A soft damp cloth should be used to clean the surfaces.
- Regularly clean the filter holder, the drip collection pan, the hot water drip spout, and the coffee pots. Do not wash the filter holder in the dish washer.

- Never immerse the machine in water: it is an electrical appliance.
- Check from time to time that the holes in the filter for espresso coffee are not obstructed. If necessary, carefully clean the filter with hot water, scrubbing with an abrasive pad.

SCALE REMOVAL



The scale contained in the water, over time, will cause plugging up of some elements in the appliance and will thereby compromise its correct functioning. The result will be that more time is required to make coffee. The formation of scale depends on the hardness of the water and on how much the coffee maker has been used. To achieve the best performance, descaling must be carried out every so often. The coffee maker has a built-in system that counts the number of cups of coffee that have been made. The ON DRIP pilot light will begin to blink when it is time to carry out descaling. To do so, proceed as follows:

- remove the anti-chlorine filter (if present) and the permanent filter from the coffee maker (so as not to bathe them with vinegar)
- Dissolve 2 dessert spoons (about 30 grams) of citric acid (available in pharmacies) in the water;
- Place the container on the heating plate;
- Press the ① DRIP/AUTO button twice, allow the equivalent of two cups to percolate and then turn off the appliance;
- Allow the solution to sit for an hour;
- Turn the appliance back on and allow the rest of the solution to percolate;
- Rinse by allowing the coffee maker to operate with only water at least three times (1 full container each time).
- Press the PROG and ① DRIP/AUTO buttons simultaneously to reset the counter to zero.

IMPORTANT: if the machine is left unconnected to the electrical mains for over two months, before using it again it is necessary to carry out the process of scale removal as described in the preceding section.

PROBLEMS DURING OPERATION

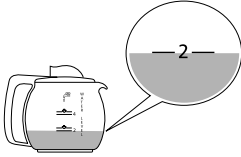
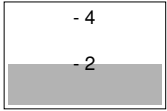
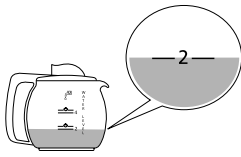
Problem	Probable Causes	Resolution
Espresso coffee longer drips out	<p>The coffee has been ground too finely</p> <p>The hole in the spout of the filter holder is plugged</p> <p>The filter is obstructed</p>	<p>Use coffee with a medium grind or the kind made for mocha coffee</p> <p>Clean the hole in the filter holder</p> <p>Clean the filter with hot water, scrubbing with an abrasive pad</p>
The milk froth does not form properly when making cappuccinos	<p>The milk is not cold enough</p> <p>The cappuccino nozzle is dirty.</p>	<p>Always use milk cold from the refrigerator</p> <p>Accurately clean the frother as described in the paragraph "Cleaning the milk frother"</p>
The coffee has a vinegary aftertaste	The machine has not been rinsed enough	Rinse the appliance as described in the chapter "Scale removal"

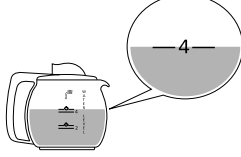
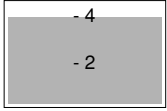
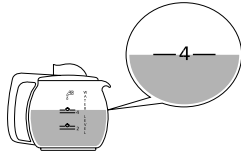
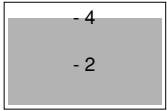
To make	The amount of water in the small coffee pot to pour into the hot water heater tank (WATER LEVEL side)	The quantity of ground coffee to put into the filter
Two coffees		
Two cappuccinos		
Four coffees		
Four cappuccinos		



Limited Warranty

What Does This Warranty Cover? We warrant each Espresso Coffee Machine to be free from defects in material and workmanship. Our obligation under this warranty is limited to replacement or repair, free of charge at our factory or authorized service centers, of any defective part or parts there of other than parts damaged in transit, which shall be returned to us, transportation prepaid. This warranty shall apply only if the Espresso Coffee Machine is used in accordance with the factory directions which accompany it.

How Long Does The Coverage Last? This warranty runs for one year from the date of delivery and applies only to the original purchaser.

What Does This Warranty Not Cover? This warranty does not cover defects or damage of the Espresso Coffee Machine which result from repairs or alterations to the machine outside our factory or authorized service centers, nor shall it apply to any Espresso Coffee Machine which has been subject to abuse, misuse, negligence or accidents. Also, consequential and incidental damages resulting from the use of this product or arising out of any breach of contract or breach of this warranty are not recoverable under this warranty. Some states do not allow the exclusion or limitation of incidental or consequential damages, so the above limitation may not apply to you.

How Do You Get Service? If repairs become necessary or spare parts are needed, please write to:

De'Longhi America Inc.

Park 80 West Plaza One, 4th floor
Saddle Brook NJ 07663
or call Service Tel. No 1-800-322-3848

or visit our internet site:

www.delonghiusa.com

The above warranty is in lieu of all other express warranties and representations; All implied warranties are limited to the applicable warranty period set forth above. This limitation does apply if you enter into an extended warranty with De'Longhi. Some states do not allow limitations on how long an implied warranty lasts, so the above exclusions connection with the sale or use of its Espresso Coffee Machine.

How Does State Law Apply? This warranty gives you specific legal rights, and you may also have other rights which vary from state to state.