

# Cuisinart®



**Grind & Brew™ Automatic Coffeemaker**

**DGB-500**

For your safety and continued enjoyment of this product, always read the instruction book carefully before using.

---

# IMPORTANT SAFEGUARDS

When using electrical appliances, basic safety precautions should always be followed to reduce the risk of fire, electric shock and/or injury to persons, including the following:

1. READ ALL INSTRUCTIONS
2. Do not touch hot surfaces. Use handles and knobs.
3. To protect against electric shock, do not place cord, plug, or base unit in water or other liquids.
4. Close supervision is necessary when any appliance is used by or near children.
5. Always unplug from outlet when not in use and before cleaning. Allow to cool before putting on or taking off parts and before cleaning the appliance.
6. Do not operate any appliance with a damaged cord or plug or after the appliance malfunctions or has been dropped or damaged in any manner. Return appliance to the nearest Cuisinart Repair Center for examination, repair, and electrical or mechanical adjustment.
7. The use of accessory attachments not recommended by Cuisinart may cause injuries.
8. Do not use outdoors.
9. Do not let cord hang over edge of table or counter, or touch hot surface.
10. Do not place on or near a hot gas or electric burner, or in a heated oven.
11. Always fill water reservoir first, then plug cord into the wall outlet. To disconnect, push the Off button, then remove plug from wall outlet.
12. Do not use appliance for other than intended use.
13. Snap lid securely onto carafe before serving any beverages.
14. Scalding may occur if the lid is removed during the brewing cycle.
15. The glass carafe is designed for use with these appliances only. It must never be used on the range top.
16. Do not set a hot carafe on a wet or cold surface.
17. Do not use a cracked carafe or a carafe having a loose or weakened handle.
18. Do not clean carafe or warming plate with cleansers, steel wool pads, or other abrasive materials.
19. **WARNING: TO REDUCE THE RISK OF FIRE OR ELECTRIC SHOCK, DO NOT REMOVE THE BASE PANEL. NO USER SERVICEABLE PARTS ARE INSIDE. REPAIR SHOULD BE DONE ONLY BY AUTHORIZED PERSONNEL.**
20. Avoid contact with moving parts.
21. Check grinder basket for presence of foreign objects before using.
22. Use the coffee grinder to grind roasted coffee beans only. Grinding other substances, such as nuts, spices or unroasted beans may dull the blade and cause poor grinding or injury.
23. Do not place cloth or otherwise restrict airflow beneath coffeemaker.
24. Use only the Cuisinart® Gold Tone Commercial Style Filter or standard #4 basket paper filter with this unit. **OTHER GOLD TONE PERMANENT FILTERS MAY CAUSE THE COFFEEMAKER TO OVERFLOW.**

## SAVE THESE INSTRUCTIONS

## FOR HOUSEHOLD USE ONLY

## WARNING: RISK OF FIRE OR ELECTRIC SHOCK



The lightning flash with arrowhead symbol, within an equilateral triangle, is intended to alert the user to the presence of uninsulated "dangerous voltage" within the product's enclosure that may be of sufficient magnitude to constitute a risk of fire or electric shock to persons.



The exclamation point within an equilateral triangle is intended to alert the user to the presence of important operating and maintenance (servicing) instructions in the literature accompanying the appliance.

## SPECIAL CORD SET INSTRUCTIONS

A short power-supply cord is provided to reduce the risks resulting from becoming entangled in or tripping over a longer cord.

Longer extension cords are available and may be used if care is exercised in their use.

If a long extension cord is used, the marked electrical rating of the extension cord must be at least as great as the electrical rating of the appliance, and the longer cord should be

arranged so that it will not drape over the countertop or tabletop where it can be pulled on by children or tripped over.

## NOTICE

This appliance has a polarized plug (one blade is wider than the other.) To reduce the risk of electric shock, this plug will fit into a polarized outlet only one way. If the plug does not fit fully into the outlet, reverse the plug. If it still does not fit, contact a qualified electrician. Do not modify the plug in any way.

## OPERATING NOTICE

Clogging and backing up of water and/or coffee in the filter basket can occur under any or a combination of any of the following conditions: The use of too finely ground coffee, using two or more paper filters, using the gold tone filter in conjunction with a paper filter or not properly cleaning coffee grounds from the gold tone filter, or allowing coffee grounds to spill over the filter.

**Caution:** Never open the filter basket during the brewing cycle, even if no water is draining from the filter basket, since extremely hot water/coffee can spill out from the filter basket and cause injury. If water/coffee is not draining from the filter basket during the brewing cycle, unplug the unit and wait 10 minutes before opening and checking the filter basket.

	<b>WARNING</b> RISK OF FIRE OR ELECTRIC SHOCK DO NOT OPEN	
<p>WARNING: TO REDUCE THE RISK OF FIRE OR ELECTRIC SHOCK, DO NOT REMOVE COVER (OR BACK) NO USER-SERVICEABLE PARTS INSIDE REPAIR SHOULD BE DONE BY AUTHORIZED SERVICE PERSONNEL ONLY</p>		

---

## INTRODUCTION

Congratulations. You've just purchased a coffeemaker that will make you want to retire your alarm clock! Wake up, instead, to the rich aroma of freshly ground, just brewed coffee, with the Cuisinart® Grind & Brew™ Automatic Coffeemaker. One of the Premier Series, this deluxe 12-cup model offers the best of Cuisinart's expert coffeemaking technology to deliver unsurpassed ease of use and rich full-bodied coffee flavor. With streamlined European styling and a graceful carafe, it's a beautiful addition to any kitchen.

The Grind & Brew™ Coffeemaker features a separate grinding assembly and filter chamber to make beans easy to add and used grounds easy to remove. A convenient "grind off" control turns the grinder off when preground coffee is used.

Fully programmable, this is the ultimate user-friendly coffeemaker. Simply add beans and water, set the flavor control to 1-4 or 5+ cups, and program start time up to 24 hours in advance. An auto-shutoff feature even lets you set the unit to turn off up to 4 hours after the brew cycle ends.

A charcoal water filter and a permanent commercial-style gold tone coffee filter allow only pure coffee flavor to flow through, and the popular Brew Pause™ feature lets you sneak a cup before the cycle is finished.

Dishwasher safe parts. Separate grind and filter chambers for easy cleanup. The freshest tasting coffee outside of a coffee bar. What more could a coffee lover ask for?

## TABLE OF CONTENTS

Important Safeguards . . . . .	Page 1
Unpacking Instructions . . . . .	Page 3
Introduction . . . . .	Page 3
The Quest for the Perfect Cup of Coffee . . . . .	Page 4
Features and Benefits . . . . .	Page 5
Control Panel . . . . .	Page 7
Programming Your Coffeemaker . . . . .	Page 8
Setting the Time . . . . .	Page 8
Programming the Auto On . . . . .	Page 8
Programming the Variable Auto Off . . . . .	Page 8
Changing the Water Filter . . . . .	Page 9
Making Coffee . . . . .	Page 9
Cleaning and Maintenance . . . . .	Page 11
Warranty . . . . .	Page 12

## IMPORTANT UNPACKING INSTRUCTIONS

1. Place the box on a large, sturdy flat surface.
2. Remove the instruction book and any other literature.
3. Turn the box so that the backside of the coffeemaker is down and slide the coffeemaker from the box.
4. After the coffeemaker has been removed, place the box out of the way and lift off the top polyfoam insert.
5. Remove cardboard insert off carafe handle.
6. Remove the cardboard insert between the carafe lid and Brew Pause mechanism by sliding it out of the unit.
7. Grasp the carafe by its handle, remove it from the heater plate and remove the polybag.
8. Remove the polybag covering the coffeemaker.

We suggest you save all packing materials in the event that future shipping of the machine is needed. Keep all plastic bags away from children.

---

# THE QUEST FOR THE PERFECT CUP OF COFFEE

It is generally agreed that there are four basic elements critical to the perfect cup of coffee:

## Element 1: Water

Coffee is 98% water. Often overlooked, the quality of the water is as important as the quality of the coffee. A good rule of thumb is that if your water doesn't taste good from the tap, it won't taste any better in your coffee. That's why Cuisinart has added a water filter to the Grind & Brew™ Coffeemaker. The charcoal water filter removes chlorine, bad tastes and odors, for the purest cup of coffee every time.

## Element 2: Coffee

While the bulk of the liquid is water, all of the flavor should be from the coffee. To achieve the same great quality cup of coffee you receive at a coffee bar, you need to use the same quality beans.

Buy the beans fresh and whole, only about two weeks' supply at a time for maximum freshness. Once the coffee bean is broken, its flavor degrades very quickly. That's why the Grind & Brew™ grinds your coffee just prior to brewing. If it is not practical to buy small supplies, we recommend you separate larger amounts of beans into one to two week portions immediately after purchase, and freeze them in airtight containers. The best way to maximize freshness is to minimize exposure to air, light and moisture. So, once beans have been removed from the freezer, maintain them in a sealed container at room temperature, since damaging condensation occurs every time the beans are removed from the freezer or refrigerator. Note that some coffee experts advise against freezing dark-roast beans, because freezing can cause the oils to coagulate. Other experts disagree. We suggest you experiment and decide for yourself.

## Element 3: Grind

The grind is critical for proper flavor extraction. If the grind is too fine, overextraction and bitterness will result. Too fine a grind may also clog the filter. If grind is too coarse, the water will pass through too quickly and the desired flavors will not be extracted. The Grind & Brew™ is preset for a medium grind, the optimal grind for this type of coffeemaker.

## Element 4: Proportion

The Grind & Brew™ makes up to twelve (12) 5-ounce cups of coffee.

### Using Whole Beans:

- We recommend you use 1 scoop of whole beans per cup. Maximum 14 scoops. For 1 or 2 cups, use 1-1/2 level scoops per cup. Adjust the recipe according to individual taste.

**DO NOT OVERFILL OR THE GRINDER COULD MALFUNCTION AND/OR THE COFFEEMAKER COULD OVERFLOW.**

### Using Pre-Ground Coffee:

Although it is preferable to use fresh, whole beans, you can make coffee in the Grind & Brew™ using pre-ground beans.

To do so, turn off the grinder by pressing the "Grind Off" button before turning on the unit.

### Our recipe:

We suggest that you use 1 level scoop of ground coffee per cup. Adjust the recipe to your taste.

**NOTE: The maximum capacity for ground coffee is 16 level scoops, using either a paper or permanent filter. Exceeding this amount may cause overflow.**

# FEATURES AND BENEFITS

## 1. Reservoir Cover

Flips back for easy filling. Removable for easy cleaning. A **Safety Interlock System** prevents operation of the unit if the Reservoir Cover is open.

## 2. Reservoir Cover Release Button

## 3. Showerhead (not shown)

Distributes water evenly over coffee, reducing temperature loss as water passes through grounds.

## 4. Control Panel

See detailed drawing

## 5. Filter Basket Compartment (see detailed drawing)

Contains:

Filter Basket

Filter Basket Cover

Filter Basket Holder

Cuisinart Gold Tone Commercial Style Filter

## 6. Filter Basket Door Release Button

## 7. Brew Pause (not shown)

Stops flow of coffee from basket when carafe is removed from heater plate so a cup can be poured in mid-brew, if desired.

## 8. Heater Plate

Scratch resistant with nonstick coating.

## 9. Carafe

The easy pour, no drip carafe has an ergonomic handle and brewed coffee markings for two to twelve cups.

## 10. Cord Storage (not shown)

## 11. Measuring Scoop with brush (not shown)

## 12. #4 Basket Paper Filters included (not shown)

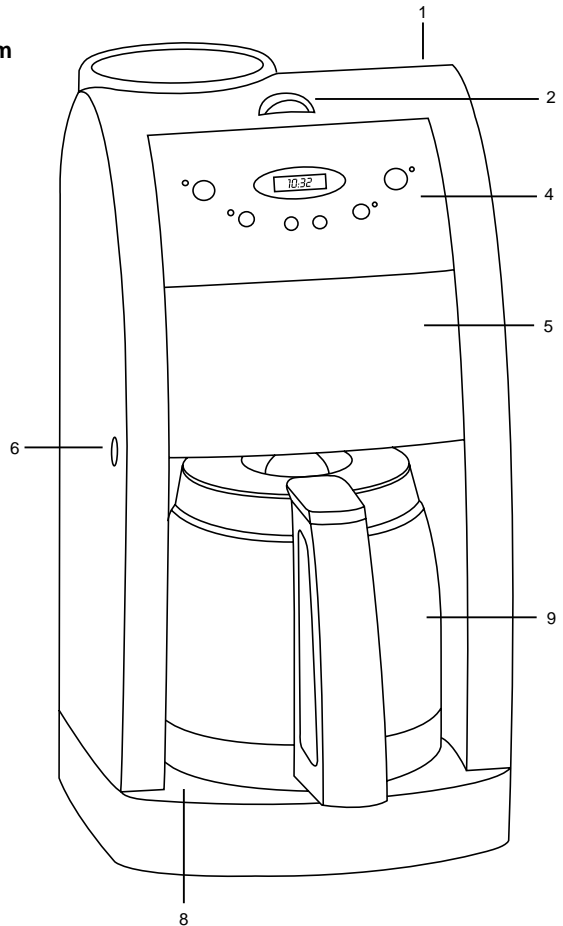

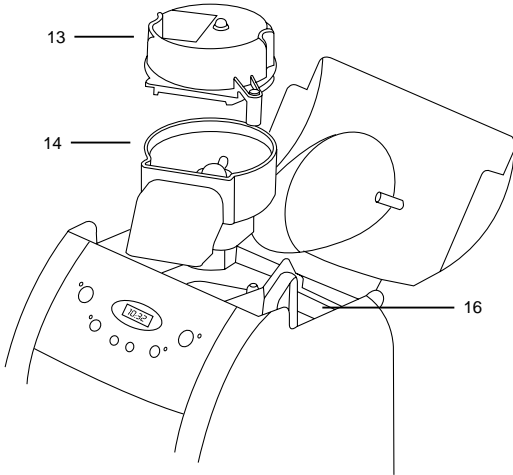

### 13. Grinder Basket Lid

Use the recess on each side of the lid to remove lid for easy addition of beans. **Note: Lid must be in place for unit to operate.**

### 14. Grinder Basket

### 15. Charcoal Water Filter (not shown)

Charcoal water filter eliminates chlorine, bad tastes and odors from tap water.

### 16. Water Reservoir with Water Level Indicator

### 17. Filter Basket Cover

To put on or remove, grasp cover in area indicated by arrows. **NOTE: COVER MUST BE IN PLACE FOR UNIT TO OPERATE CORRECTLY. Cover becomes hot after coffee is brewed. Use caution when removing cover.**

### 18. Gold Tone Cuisinart Commercial Style Filter (not shown)

**A note about filters:** When using our permanent filter, be sure that the handle is positioned toward the front of the unit. If you do not, the handle may interfere with the flow of coffee into the filter basket.

**Also note, using our permanent gold-tone filter will allow some fine coffee grounds to fall into the coffee carafe. This will appear as sediment in the carafe.**

### 19. Filter Basket

Holds our commercial style permanent filter or paper filter. **NOTE: FILTER BASKET HOLDER MUST BE IN PLACE FOR UNIT TO OPERATE CORRECTLY.** Removable for easy cleaning.

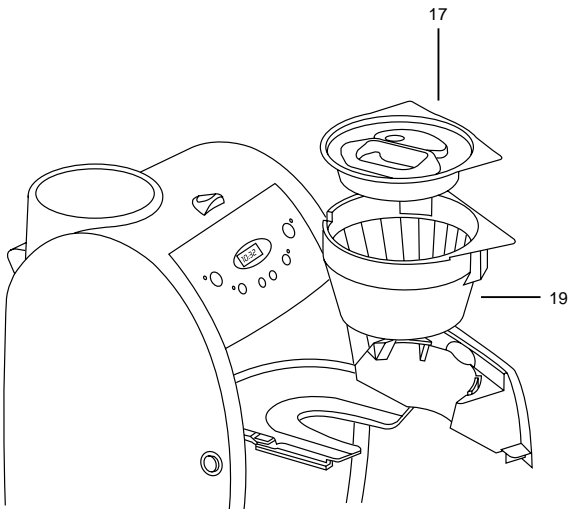

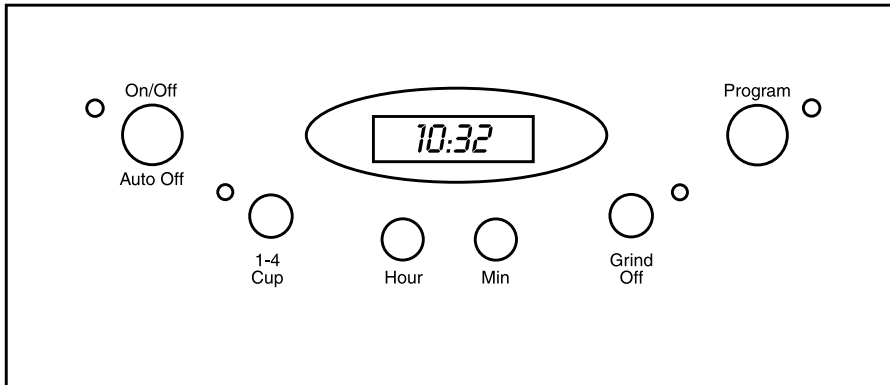

## Control Panel

(Detailed programming instructions are on pages 8 and 9)

### 1. On/Off/Set Auto-Shutoff Switch with LED Indicator:

a. Audible Tone (not shown): The Automatic Grind & Brew™ coffeemaker is equipped with an audible tone which will sound 5 times when the coffee has completed brewing (coffee may continue to stream from the filter for several seconds thereafter).

b. Auto-Shutoff Tone (not shown): Unit will sound twice at end of programmed auto-shutoff period (when unit has shut itself off completely).

### 2. Low Cups Setting with LED Indicator:

Set to "1-4 cups" to improve extraction and flavor when making fewer than 5 cups of coffee.

### 3. Hours Set/Minutes Set

Press and hold either hour or minute button for approximately 2 seconds to enter Time Set Mode.

### 5. Clock Display:

Displays time of day, program setting when program button is depressed, or Auto-Shutoff time when On/Off button is depressed.

### 6. Grind Off with LED Indicator:

Use to turn off the grinder when using pre-ground coffee.

### 7. Program Setting with LED Indicator:

Press to display program setting or to set for programmed brewing.



---

# PROGRAMMING YOUR COFFEEMAKER

## 1. Setting the Clock

When the coffeemaker is plugged in, 12:00 will appear until you set the time.

Entering "Time Set" Mode:

To set the time, hold down either the "Hours" or "Minutes" button until the clock begins flashing (about 2 seconds). You are now in the "Time Set" mode and can operate either button to achieve the desired setting. The buttons can be held down to scroll through the digits, or pressed and released lightly to advance one digit at a time.

When scrolling, the numbers will advance slowly at first and then speed up to the rate of about three per second. When the number displayed approaches the desired setting, release the button and press repeatedly to advance one digit at a time. Be careful to make sure that the PM indicator is on if a PM time is desired.

Exiting "Time Set" Mode:

The "Time Set" mode can be exited in one of two ways:

1. Press any button besides the "Hours" or "Minutes" button. This will exit the "Time Set" and activate the selected function.
2. Do nothing. If neither the "Hours" nor "Minutes" button is pressed for a period of five seconds, the "Time Set" mode will be exited.

## 2. Setting the Program Time:

When you press the "Program Set" button, it displays the current program time (default time 12:00 p.m.).

Entering "Set Program Time" Mode:

Press and hold the "Program Set" button (about 2 seconds) until the green light and LCD display begin to flash. This signals that you have entered the "Set Program Time" mode. The desired time can be set by pressing the "Hours" and "Minutes" buttons to scroll forward through the digits. Pressing and holding either button will allow you

to scroll continuously, slowly at first, and then to accelerate to the rate of about three digits per second. As the desired time setting approaches, release the button and then press repeatedly to advance one digit at a time. The coffeemaker will start to brew at the programmed time. The "Program" mode cannot be entered if the coffeemaker is in its "brew" or "keep warm" cycle.

Exiting "Set Program Time" Mode:

"Set Program Time" may be exited in any of three ways:

1. Press the "Program Set" button. This will cause the coffeemaker to revert to its previous state. If it was OFF, it will return to the OFF position. If "Programmed", it will revert to this state, and so on. This is a safety feature.
2. Press any other button (except "Hours" or "Minutes"). "Set Program Time" will be exited and the function of that button will be executed.
3. Do nothing. If neither the "Hours" nor "Minutes" button is pressed for a period of five seconds, the "Set Program Time" mode will be exited and the programmed setting will be in effect.

## PROGRAMMING AUTOMATIC SHUTOFF TIME

The Automatic Shutoff Time can be programmed anywhere from immediate shutoff after completion of the brew cycle up to four hours. When the coffeemaker shuts itself off, two tones will sound. Two hours is the default time. The 0:00 setting shuts the unit off immediately after brewing is complete. To check the current setting, press and hold the "On/Off" button and the Automatic Shutoff Time will be displayed.

To change the preset time, press and hold the "On/Off" button until the red "power" light and LCD display begin to flash. This signals that you have entered the "Set Automatic Shutoff" mode.

Press the "Hours" and "Minutes" buttons to scroll forward through the digits until desired time appears. The first setting which appears is preset at "2:00". When it's at "4:00", the next press key of "hour" will roll back to "0:00", since four hours is the maximum Automatic Shutoff setting. Pressing and

holding either button will allow you to scroll continuously, slowly at first, and then to accelerate to the rate of about three digits per second. As the desired time setting approaches, release the button and then press repeatedly to advance one digit at a time.

The Automatic Shutoff Time (ASO) may be programmed either before or during coffee brewing. You may also re-program the ASO time when brewing has been completed. If you do so, the Automatic Grind & Brew™ will automatically account for any time that has already elapsed after brewing. For example, if you set the ASO for 40 minutes and 25 minutes have already elapsed, the Grind & Brew™ will shut off automatically after 15 minutes (40 minutes minus the 25 elapsed equals 15 minutes).

## 1. Insert the Water Filter

- a. Remove the filter from polybag and soak in cold tap water for 15 minutes.
- b. Remove the water filter holder from the coffeemaker by lifting it out of the reservoir area with your thumb and forefinger.
- c. Grasp stem in one hand. Using thumb of other hand, gently press down and pull toward you. Compartment will flip open.
- d. Place the filter in the holder and close the water filter holder; you will hear a snap indicating it is in place.

**NOTE:** Caution must be used when inserting the charcoal filter. Improper placement in the holder can cause tearing of the filter skin.

- e. Hold the filter under cold running tap water for 10 seconds to flush. You should place the hole openings in the side of the unit directly under the water stream.
- f. Allow the filter to drain completely.
- g. Replace the water filter holder in the reservoir area of the coffeemaker, pushing it all the way down to the base of the unit, along the reservoir wall.

Note: We recommend changing the water filter every 60 days or 60 uses, more often if you have hard water.

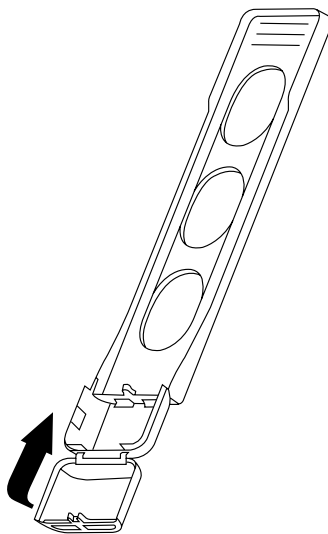

Replacement water filters can be purchased in stores or by calling customer service or through the Cuisinart web site.

## TURNING OFF GRIND FUNCTION

To turn off the grinding function, press the “Grind Off” button. An amber LED will be illuminated. Then press the On button.

## MAKING COFFEE

Before you make the first pot of coffee in your new Cuisinart® Grind & Brew™ Automatic coffeemaker, we recommend operating the coffeemaker once, using only water and a paper filter. This will remove any dust or residues which remain in the system from the manufacturing process.

### 1. Fill the Water Reservoir

Open the reservoir lid by pushing the release button and lifting up. Pour the desired amount of water in the reservoir using the step water indicator located at the rear of the reservoir.

### 2. Add Beans

Lift the grinder basket lid, using the recess on either side. Fill the basket with the desired quantity of beans.

---

(Use 1 level scoop of whole beans per cup. For 1 or 4 cups, use 1-1/2 level scoops per cup. **Maximum capacity is 14 level scoops. Do not over fill or the grinder could malfunction and/or the coffeemaker may overflow.** This is our suggested recipe. Adjust the recipe to taste.)

### 3. Open Filter Door

Place a #4 basket paper filter or Cuisinart's® commercial style permanent filter in the basket.

**Note: When using the Cuisinart filter, be sure that the filter handle is facing away from the grinder basket. If you do not do so, the handle may interfere with the flow of ground coffee into the filter basket. Also note: a permanent filter may allow some ground coffee to flow into carafe.**

**The filter holder will help to keep the filter open, but when using a paper filter, be sure that the filter is completely open while touching the side walls and bottom of the basket.**

Place filter basket lid in place. Close filter door.

### 4. Close the Reservoir Lid

Press down to lock. The Grind & Brew™ Automatic coffeemaker is equipped with a Safety Interlock System. The Grind & Brew™ coffeemaker will not operate if the cover of the unit is open or the grinder cover is left out. Because grinder blades spin during operation, the Grind & Brew™ coffeemaker will not operate if the cover of the unit is open. If you try to turn the unit on with the cover open, the unit will beep continuously until the missing parts are installed and you close the lid. The unit will also beep if you open the lid during the brewing process. The grinder will stop grinding or, if brewing, the brewing will stop. Once the missing parts are installed and the cover is closed, the beeping stops. The brewing process can be restarted by pressing the "On" button. Restarting the process will not affect coffee results. If you do not want the grinder to come on again, press the "Grind Off" button before pressing the "On" button. Once the lid is closed, the beeping will stop, and the grind and brew process will start again from the beginning.

### 5. Before Brewing Coffee

Make sure you have replaced the glass carafe in its position on the warming plate and have placed a filter in the filter basket. Plug the cord into an electrical outlet. "12:00" will appear until you set the time. This will not interfere with the operation of the coffeemaker. To set clock, see the "Programming Your Coffeemaker" section, page 8.

Check to see that the Automatic-Off Time is as you desire. For information on these features see "Programming Your Coffeemaker" on page 8.

### 6. Power Unit

a) Immediate grinding and brewing:

Press the ON button. The indicator will light and the process will begin.

b) Programmed Brewing:

Press the "Program" button. The indicator will light and the display will show the programmed time for as long as the button is depressed. The display reverts back to time of day once the button is released. To set the programmed time, see "Programming Your Coffeemaker" on page 8.

### 7. Select Cups Setting

The 1-4 cup setting button is used when you make small amounts of coffee. Normal coffeemakers will produce a colder batch of coffee when smaller amounts are made, because the heater doesn't have enough time to properly 'warm up' to heat a small amount.

The 1-4 setting basically 'double heats' the water, making your smaller amount as piping hot as a full pot would be.

**To use:** When making a smaller amount, press the 1-4 button on the control panel after turning on the unit. The indicator light will illuminate. Note that the 1-4 button can be set at any time.

### 8. During and After Brewing

The Brew Pause™ feature allows you to remove the carafe from the heater during mid-brew. The brewing process does not stop during this period; only the flow of coffee from the basket stops. **Do not remove the carafe for longer**

than 30 seconds or the coffee may overflow the basket. While we offer this feature, we do not recommend that you pour coffee before the cycle has reached completion, since the coffee brewed at the beginning of the cycle has a flavor profile which is very different from the coffee made at the end of the cycle. Removing a cup during the brewing cycle will alter the flavor of the finished pot.

Once the coffee has finished brewing, stir it before serving to blend the flavors. The coffee at the bottom of the carafe will be somewhat stronger than the coffee at the top.

When the brewing cycle is completed, five beeps will sound. Coffee will continue to stream from the filter for several seconds.

After brewing, the heater plate will keep the coffee at about 180°-185°F. We recommend transferring the coffee to a thermal carafe preheated with hot water, if the coffee is not going to be drunk within 20 minutes.

## TO MAKE COFFEE WITH PRE-GROUND BEANS:

Follow step #1 from Making Coffee section on page 9 then continue as follows:

2. Open filter door. Add ground coffee to our permanent or #4 basket paper filter. Our recipe suggestion: Use 1 level scoop of ground coffee per cup. Adjust the recipe according to your individual taste.

**NOTE:** The maximum capacity for ground coffee is 16 level scoops, using either a paper or permanent filter. Exceeding that amount may cause overflow if the coffee is too finely ground.

3. Place filter basket lid in place. Close filter door.
4. Follow instructions 5 through 8 from the Making Coffee section.
5. Press the "Grind Off" button. When this function is activated, an amber LED will be illuminated. Then press the "ON" button.

## CLEANING AND MAINTENANCE

### COMPLETELY CLEAN AND DRY ALL PARTS AFTER EVERY USE.

Always turn coffeemaker OFF and remove the plug from the electrical outlet before cleaning.

Open the reservoir lid\*. Remove the grinder basket lid by using the recessed area on each side of the lid. Then remove Grinder Basket. Open Filter Basket Door. Remove Filter Basket Cover, Filter Basket and Filter Basket holder.

The grinder basket, grinder basket lid, filter basket and filter basket cover can be washed in warm soapy water and rinsed thoroughly, or cleaned in the upper rack of the dishwasher. Dry all parts after every use.

**Do not put any water in the unit once the grinder basket has been removed. Wipe the area under the grinder basket with a damp cloth. If water gets into the grinder motor, the motor may become damaged and may malfunction.**

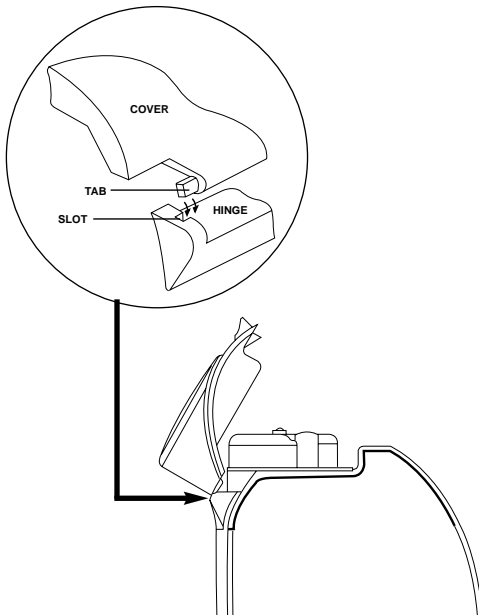

---

Once clean, reverse the above steps.

Remove the carafe from the warming plate. Discard any remaining coffee. The carafe and lid can be washed in warm soapy water and rinsed thoroughly, or placed in a dishwasher. The carafe and carafe lid should be placed on the upper rack only.

Do not use scouring agents or harsh cleansers on any part of the coffeemaker.

Never immerse base unit in water or other liquid. To clean base, simply wipe with a clean, damp cloth and dry before storing. Wipe warming plate with a clean, damp cloth. Never use rough, abrasive materials or cleansers to clean the warming plate. Do not dry the inside of the water reservoir with a cloth, as lint may remain.

\* Note: Reservoir lid can also be removed for easy cleaning. Open the lid 60° and gently pull toward you. To replace, reverse steps.

## DECALCIFICATION

Decalcification refers to removing the calcium deposits which form over time on the metal parts of the coffeemaker.

For best performance from your coffeemaker, decalcify the base unit from time to time. The frequency depends upon the hardness of your tap water and how often you use the coffeemaker.

To clean, fill the water reservoir to capacity with a mixture of 1/3 white vinegar and 2/3 water. Turn the coffeemaker on by pressing the ON button. One cycle should be sufficient to adequately clean the coffeemaker. When the cycle is completed and the five beeps sound, turn coffeemaker off. Repeat operation this time using fresh cold water.

## WARRANTY

### LIMITED THREE-YEAR WARRANTY

This warranty supersedes all previous warranties on the Cuisinart® Grind & Brew™ Automatic Coffeemaker.

This warranty is available to consumers only. You are a consumer if you own a Cuisinart® Grind & Brew™ Automatic Coffeemaker that was purchased at retail for personal, family or household use. Except as otherwise required under applicable state law, this warranty is not available to retailers or other commercial purchasers or owners.

We warrant that your Cuisinart® Grind & Brew™ Automatic Coffeemaker will be free of defects in material or workmanship under normal home use for three years from the date of original purchase.

We suggest that you complete and return the enclosed warranty registration card promptly to facilitate verification of the date of original purchase. However, return of the warranty registration is not a condition of these warranties.

If your coffeemaker should prove to be defective within the warranty period, we will repair it (or, if we think it necessary, replace it) without charge to you. To obtain warranty service, please call our Consumer Service Center toll-free at 800-726-0190 or write to:

Cuisinart  
150 Milford Road  
East Windsor, NJ 08520

To facilitate the speed and accuracy of your return, please also enclose \$10.00 for shipping and handling of the product (California residents need only supply proof of purchase and should call 1-800-726-0190 for shipping instructions). Please also be sure to include a return address, description of the product defect, product serial number, and any other information pertinent to the product's return. Please pay by check or money order.

Your Cuisinart® coffeemaker has been manufactured to strict specifications and has been designed for use with the Cuisinart®

---

coffeemaker authorized accessories and replacement parts for your model. These warranties expressly exclude any defects or damages caused by accessories, replacement parts or repair service other than those that have been authorized by Cuisinart.

These warranties exclude all incidental or consequential damages. Some states do not allow the exclusion of or limitation of incidental or consequential damages, so the foregoing limitation or exclusion may not apply to you.

### **CALIFORNIA RESIDENTS ONLY**

California law provides that for In-Warranty Service, California residents have the option of returning a nonconforming product (A) to the store where it was purchased or (B) to another retail store which sells Cuisinart products of the same type. The retail store shall then, at its choice, either repair the product, refer the consumer to an independent repair facility, replace the product, or refund the purchase price less the amount directly attributable to the consumer's prior usage of the product. If either of the above two options does not result in the appropriate relief to the consumer, the consumer may then take the product to an independent repair facility if service or repair can be economically accomplished. Cuisinart and not the consumer will be responsible for the reasonable cost of such service, repair, replacement, or refund for nonconforming products under warranty.

California residents may also, at their preference, return nonconforming products directly to Cuisinart for repair or, if necessary, replacement by calling our Consumer Service Center toll-free at 800-726-0190. Cuisinart will be responsible for the cost of the repair, replacement, and shipping and handling for such nonconforming products under warranty.

### **BEFORE RETURNING YOUR CUISINART PRODUCT**

**Important:** If the nonconforming product is to be serviced by someone other than Cuisinart's Authorized Service Center, please remind the servicer to call our Consumer Service Center to ensure that the problem is properly diagnosed, the product serviced with the correct parts, and to ensure that the product is still under warranty.

# Cuisinart

SAVOR THE GOOD LIFE™



Coffeemakers



Food Processors



Toaster Ovens



Blenders



Cookware



Ice Cream Makers

Discover the complete line of Cuisinart® brand premier kitchen appliances including food processors, mini food processors, hand mixers, blenders, toasters, coffeemakers, cookware, ice cream makers and toaster ovens at

[www.cuisinart.com](http://www.cuisinart.com)

©2002 Cuisinart  
Cuisinart® is a registered  
trademark of Cuisinart.

Cuisinart  
150 Milford Road  
East Windsor, NJ 08520  
Printed in China  
02CU13167

IB-4335