

BRAUN

KF 190



AromaSelect Cappuccino

Type 3123

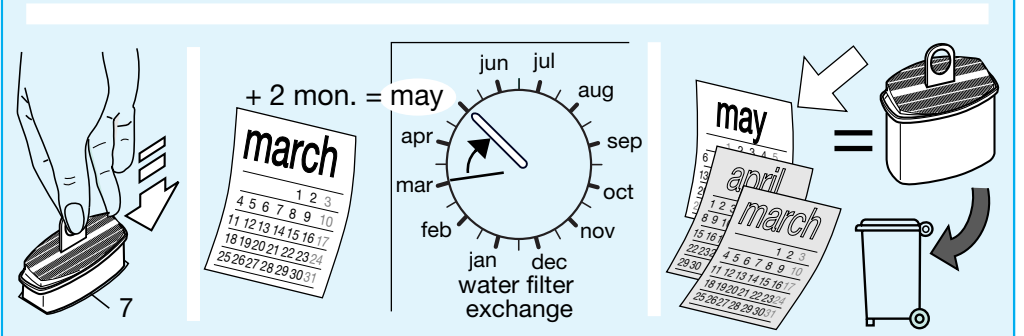
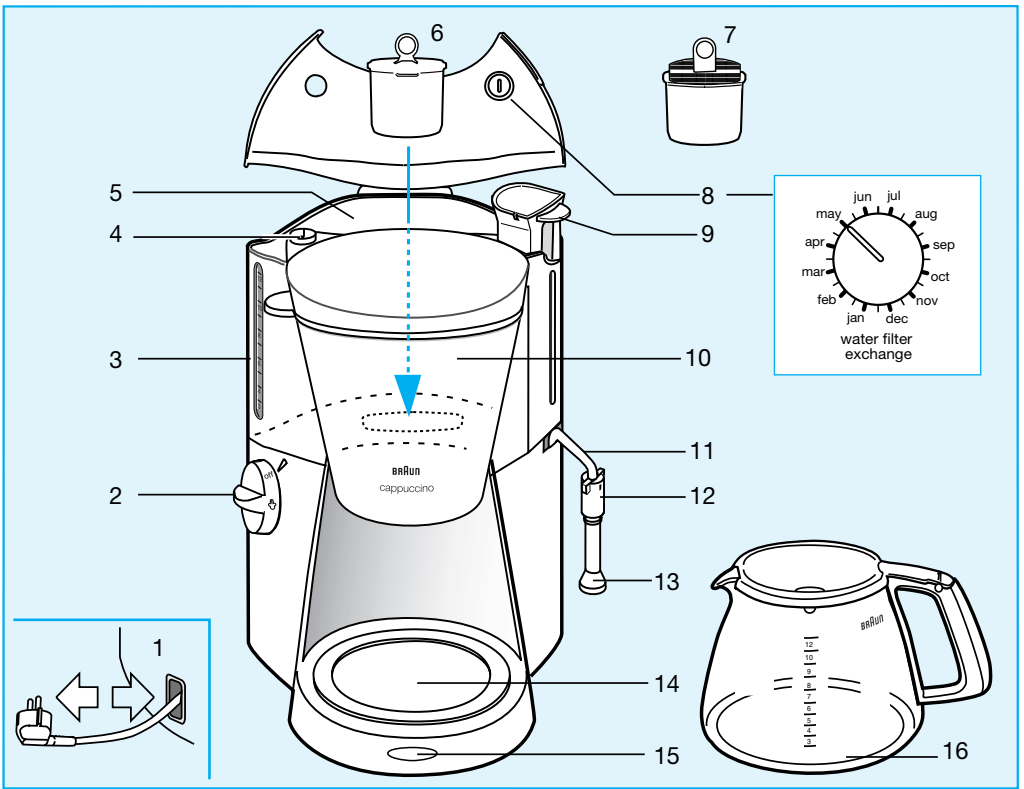

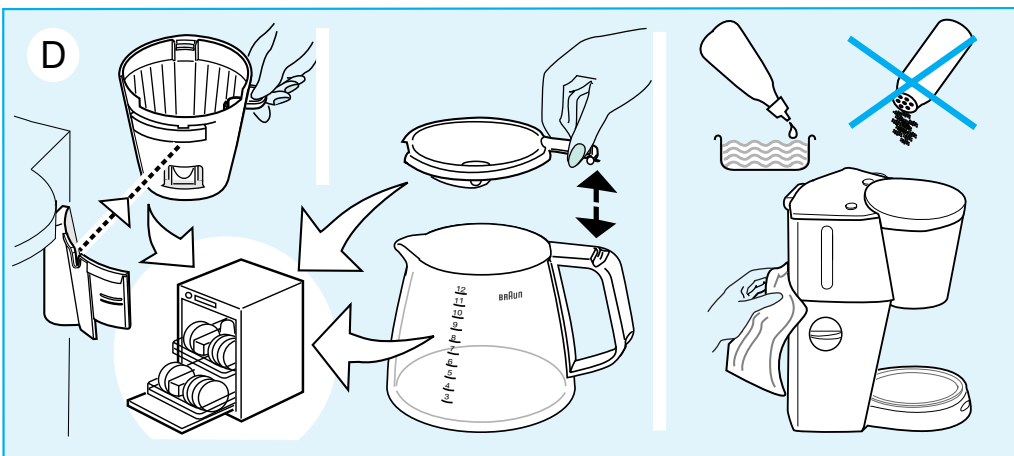
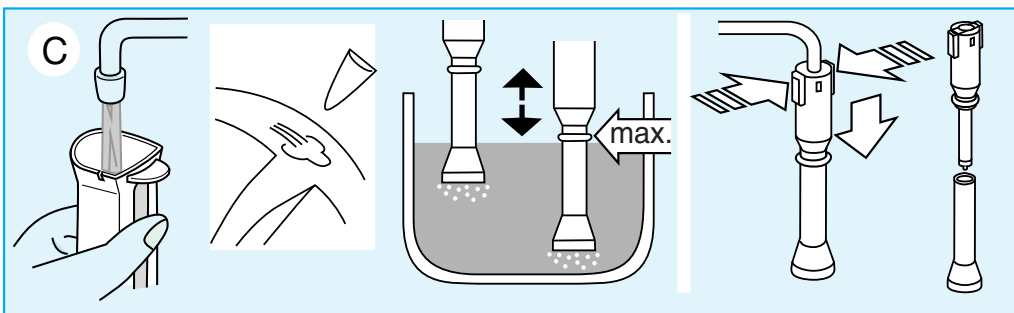
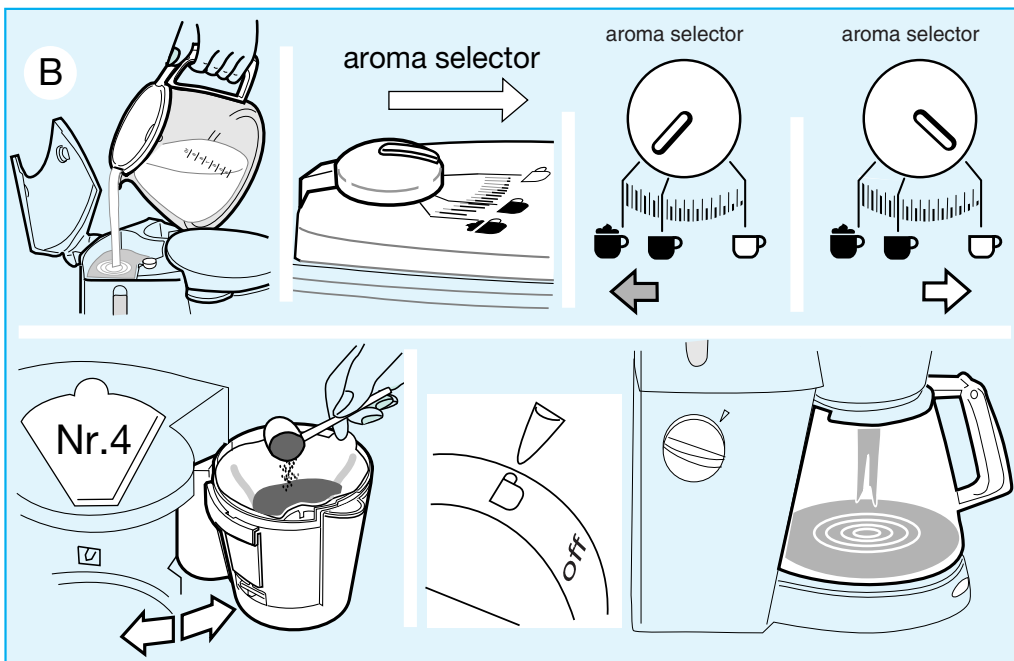



Braun Infoline

Deutsch	6, 34, 40
English	8, 34, 40
Français	10, 34, 40
Español	12, 35, 40
Português	14, 35, 40
Italiano	16, 35, 40
Nederlands	18, 36, 40
Dansk	20, 36, 40
Norsk	22, 36, 40
Svenska	24, 37, 40
Suomi	26, 37, 40
Ελληνικά	28, 37, 40
Русский	30, 37, 40
Українська	32, 38, 40

(D) Haben Sie Fragen zu diesem Produkt?
Rufen Sie an: (in Deutschland und

(A) Österreich zum Nulltarif)
00 800 27 28 64 63
00 800 BRAUNINFOLINE

(CH) **08 44 - 88 40 10**

(E) Servicio al consumidor para España:
9 01-11 61 84

(P) Serviço ao Consumidor para Portugal:
080820 00 33

(I) Servizio consumatori:
(02) 6 67 81 o (02) 6 67 86 23

(NL) Heeft u vragen over dit produkt?
Bel Braun Consumenten-infolijn:
(070) 4 13 16 58

(B) Vous avez des questions sur ce produit?
Appelez Braun Belgique
(02) 718 29 09

(DK) Har du spørgsmål om produktet? Så ring
70 15 00 13

(N) Spørsmål om dette produktet? Ring
88 02 55 03

(S) Frågor om apparaten? Ring Kundservice
031 - 89 06 50

(FIN) Onko Sinulla kysyttävää tuotteesta? Soita
0203 77877

Internet:
www.braun.com

English

Our products are engineered to meet the highest standards of quality, functionality and design. We hope you thoroughly enjoy your new Braun appliance.

Caution

Please read the use instructions carefully and completely before using the appliance.

Keep the appliance out of reach of children. Before plugging into a socket, check whether your voltage corresponds with the voltage printed on the bottom of the appliance.

Avoid touching hot parts, especially the hotplate. Never let the cord come in contact with the hotplate. Do not put the carafe on other heated surfaces (such as stove plates, hot trays, etc.). Be careful when operating the function selector because hot steam will escape.

Before you start preparing coffee a second time, always allow the coffeemaker to cool down for approx. 5 minutes (switch off the appliance), otherwise steam can develop when filling with cold water.

Braun electric appliances meet applicable safety standards. Repairs or the replacement of the mains cord must only be done by authorised service personnel. Faulty, unqualified repair work may cause accidents or injury to the user.

This appliance was constructed to process normal household quantities. Always use cold water.

Maximum cups

12 cups (à 125 ml)
18 cups (à 83 ml)

Description

- 1 Cord/cord storage
- 2 Function switch
 - ☐ = coffee
 - off
 - ☞ = steam
- 3 Water level indicator
- 4 Aroma selector
 - ☐ = mild taste
 - ☛ = strong taste
 - ☛☛ = cappuccino
- 5 Large tank (coffee)
- 6 Space compensator
- 7 Water filter cartridge
- 8 Dial for water filter exchange
- 9 Removable tank (steam)
- 10 Filter holder
- 11 Steam tube
- 12 Frothing attachment
- 13 Removable jet
- 14 Hotplate
- 15 Pilot light
- 16 Carafe with lid

A Setting into operation

When using the water filter cartridge (7) and exchanging it regularly, you normally will not need to decalcify. However, if your coffeemaker takes much longer than normal to brew, the coffee section has to be decalcified.

To install the water filter cartridge, remove the space compensator (6) from the water container and insert the water filter cartridge (7). (Make sure to keep the space compensator as it has to be installed in the water container whenever the water filter cartridge has been removed, e.g. for decalcification).

After having installed a new filter, operate the appliance with the maximum amount of water without coffee grounds.

Replace the water filter cartridge with a new one after two months of regularly using the coffeemaker. You may set the dial (8) to the month in which the water filter has to be exchanged.

N.B.

Before using the appliance for the first time, after a longer time of not using it, fill both tanks (5, 9) with water and let it run through.

B Making coffee

With this appliance you can vary the way you drink your favourite cup of coffee. You can either prepare coffee, cappuccino, café latte, etc. or use different types of coffee (flavoured, blended, espresso, etc.).

Fill the large tank (5) with cold water, put a No. 4 paper filter into the filter holder and fill with coffee grounds. Set the aroma selector (4) according to your preference. If you want to brew coffee for cappuccino, set the aroma selector to «☛☛».

Put the carafe on the hotplate and switch on the appliance by turning the function switch to the «☐» symbol.

Brewing time per cup: approximately 1 minute.

As long as the function switch is on position «☐», the pilot light illuminates and the hotplate heats to keep the coffee hot.

C Frothing milk or heating up liquids

Fill the small tank (9) with water. Swing out the frothing attachment. Hold a heat-resistant receptacle filled half-way with milk under the frothing attachment so that the removable jet is immersed in the milk.

However, do not immerse beyond the jet. Turn the function switch to position «☞».

When the froth starts to raise, lower the receptacle in order to keep the ring above the froth. After frothing, turn the function switch to position «off».

However, if you want to keep prepared coffee warm, turn the function switch back to «☐».

To heat up liquids (milk or chocolate), remove the jet (13) and immerse the frothing attachment.

It is best to clean the frothing attachment (12) and its removable jet (13) immediately after frothing. Remove the frothing attachment by squeezing both plastic pins and pulling it off downwards. Then pull off the removable jet from the frothing attachment.

After cleaning, push the jet onto the frothing attachment and put the frothing attachment back on the tube by clicking it in.

D Cleaning

Always unplug the appliance before cleaning. Never clean the appliance under running water, nor immerse it in water; only clean it with a damp cloth. All removable parts can be cleaned in a dishwasher.

E Decalcifying (without illustrations)

With decreasing frothing performance or prolonged coffee brewing time, you should decalcify both the steam section and the coffee section of the appliance.

For decalcification use only commercial vinegar essence solution of 25%.

N.B.: If you have installed a water filter cartridge (7), you absolutely have to replace it with the space compensator (6) for the decalcification process.

First decalcify the steam section:

For decalcification of the steam section fill the small tank (9) half with water and fill up to the maximum with vinegar essence.

Remove the frothing attachment and hold the steam tube into a water filled receptacle.

Make sure to immerse the steam tube opening in the water in order to prevent steam from escaping which can cause an offensive smell.

Stop the pumping action after about half a minute and allow the solution to rest for 10 minutes. Then pump through completely. Repeat the procedure twice.

After pumping the decalcifying solution through the tube, refill the small tank with cold water at least twice and pump it through with the frothing attachment removed.

Then decalcify the coffee section:

1. Fill the large tank (5) to the mark for 3 cups with cold water.
2. Add vinegar essence to the mark for 6 cups.
3. Place the carafe with the lid onto the hotplate (14), close the filter holder (10) (without any type of filter) and switch on the coffeemaker.
4. Allow the decalcifying solution to run through.
5. Repeat this procedure at least three times with a newly prepared descaling solution, in order to remove all calcium residues.
6. Allow the maximum amount of fresh cold water to run through at least twice to cleanse the machine.

Subject to change without notice.

This product conforms to the EMC-Requirements as laid down by the Council Directive 89/336/EEC and to the Low Voltage Regulation (73/23 EEC).



Deutsch

Garantie

Als Hersteller übernehmen wir für dieses Gerät – **nach Wahl des Käufers zusätzlich zu den gesetzlichen Gewährleistungsansprüchen gegen den Verkäufer** – eine Garantie von 1 Jahr ab Kaufdatum.

Innerhalb dieser Garantiezeit beseitigen wir nach unserer Wahl durch Reparatur oder Austausch des Gerätes unentgeltlich alle Mängel, die auf Material- oder Herstellungsfehlern beruhen.

Von der Garantie sind ausgenommen: Schäden, die auf unsachgemäßen Gebrauch (Betrieb mit falscher Stromart/Spannung, Anschlüsse an ungeeignete Stromquelle, Bruch) zurückzuführen sind, normaler Verschleiß und Mängel, die den Wert oder die Gebrauchstauglichkeit des Gerätes nur unwesentlich beeinträchtigen.

Bei Eingriffen nicht von uns autorisierter Stellen oder bei Verwendung anderer als original Braun Ersatzteile erlischt die Garantie.

Die Garantie tritt nur in Kraft, wenn das Kaufdatum durch Stempel und Unterschrift des Händlers auf der Garantiekarte und der Registrierkarte bestätigt ist. Sie kann in allen Ländern in Anspruch genommen werden, in denen dieses Gerät von Braun oder ihren autorisierten Händlern verkauft wird.

Im Garantiefall senden Sie bitte das vollständige Gerät mit der ausgefüllten Garantiekarte einem unserer autorisierten Servicehändler oder an eine Braun Kundendienststelle. Die Anschriften für Deutschland können Sie zum Nulltarif unter der Rufnummer 00 800 / 27 28 64 63 erfragen. Wir stehen Ihnen hier mit unserer Braun Infoline auch für weitere Fragen zu unseren Produkten gern zur Verfügung.

English

Guarantee

We grant a 1 year guarantee on the product commencing on the date of purchase.

Within the guarantee period we will eliminate, free of charge, any defects in the appliance resulting from faults in material or workmanship either by repairing, or exchanging parts or exchanging the whole appliance as we may choose.

Not covered by this guarantee: damage arising from improper use (operation with incorrect current/voltage, plugging it into an unsuitable power point, breakage), normal wear and defects which have a negligible effect on the value or operation of the appliance.

The guarantee becomes void if repairs are undertaken by unauthorized persons and if original Braun parts are not used.

The guarantee only comes into force if the date of purchase is confirmed by the dealer's stamp and signature on the guarantee card and registration card.

This guarantee extends to every country where this appliance is supplied by Braun or its appointed distributor and where no import restrictions or other legal regulations hinder or prevent service being given under guarantee.

Service under the guarantee does not affect the expiry date of the guarantee. The guarantee on parts or entire appliances which are exchanged ends when the guarantee on this appliance expires.

In the event of a claim under this guarantee, hand in the complete appliance with the valid guarantee card to your dealer, or send both to the nearest Braun Customer Service Centre.

All other claims including for damages resulting from this guarantee are excluded unless our liability is legally mandatory.

Those claims arising out of the sales contract with the vendor are not affected by this guarantee.

For UK only:

This guarantee in no way affects your rights under statutory law.

Français

Garantie

Nous accordons une garantie d'un an sur ce produit, à partir de la date d'achat.

Pendant la durée de la garantie, Braun prendra gratuitement à sa charge la réparation des vices de fabrication ou de matières, en se réservant le droit de décider si certaines pièces doivent être réparées ou échangées, ou encore si l'appareil lui-même doit être échangé.

Les dommages occasionnés par une utilisation inadéquate (branchement sur courant continu, erreur de voltage, prise inappropriée, choc), l'usure normale et les défauts ne portant préjudice ni au bon fonctionnement ni à la valeur de l'appareil excluent toute prétention à la garantie.

La garantie devient caduque si des réparations ont été effectuées par des personnes non agréées par Braun et si des pièces de rechange ne provenant pas de Braun ont été utilisées.

La garantie ne sera valable que si, la date d'achat ainsi que le cachet et la signature du magasin figurent sur la carte de garantie et la carte de contrôle.

Cette garantie est reconnue dans tous les pays où Braun ou son distributeur exclusif commercialise