

BRAUN

5312

5314

5315

5316

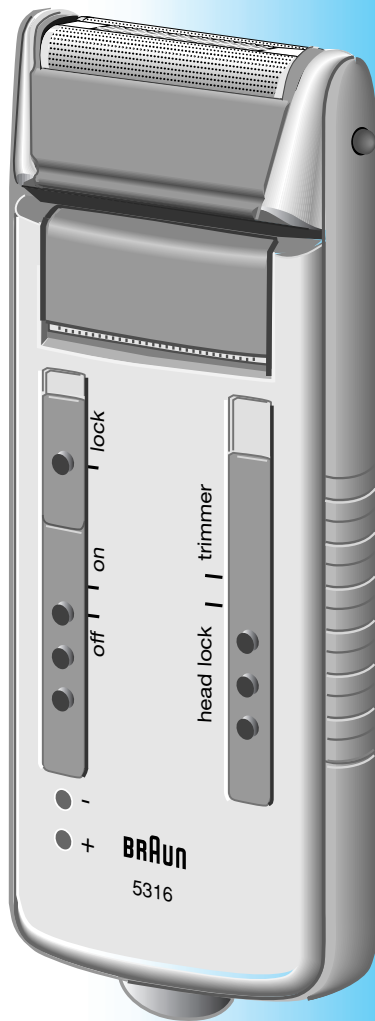

Flex Integral

Type 5466
Type 5465



Braun Infoline

Deutsch	4, 68, 74
English	8, 68, 74
Français	12, 68, 74
Español	16, 69, 74
Português	20, 69, 74
Italiano	24, 70, 74
Nederlands	28, 70, 74
Dansk	32, 70, 74
Norsk	36, 70, 74
Svenska	40, 71, 74
Suomi	44, 71, 74
Magyar	48, 71, 74
Český	52, 71, 74
Polski	56, 72, 74
Türkçe	60, 74
Ελληνικά	64, 73, 74

Internet:
www.braun.com

- (D)** Haben Sie Fragen zu diesem Produkt?
- (A)** Rufen Sie an (gebührenfrei):
00 800 27 28 64 63
00 800 BRAUNINFOLINE
- (CH)** **08 44 - 88 40 10**
- (E)** Servicio al consumidor para España:
9 01-11 61 84
- (P)** Serviço ao Consumidor para Portugal:
808 20 00 33
- (I)** Servizio consumatori:
(02) 6 67 86 23
- (NL)** Heeft u vragen over dit produkt?
Bel Braun Consumenten-infolijn:
(070) 4 13 16 58
- (B)** Vous avez des questions sur ce produit ?
Appelez Braun Belgique
(02) 711 92 11
- (DK)** Har du spørgsmål om produktet? Så ring
70 15 00 13
- (N)** Spørsmål om dette produktet? Ring
88 02 55 03
- (S)** Frågor om apparaten? Ring Kundservice
020 - 21 33 21
- (FIN)** Onko Sinulla kysyttävää tuotteesta? Soita
0203 77877
- (TR)** Müşteri Hizmetleri Merkezi:
0212 - 473 75 85

Flex Integral 5316

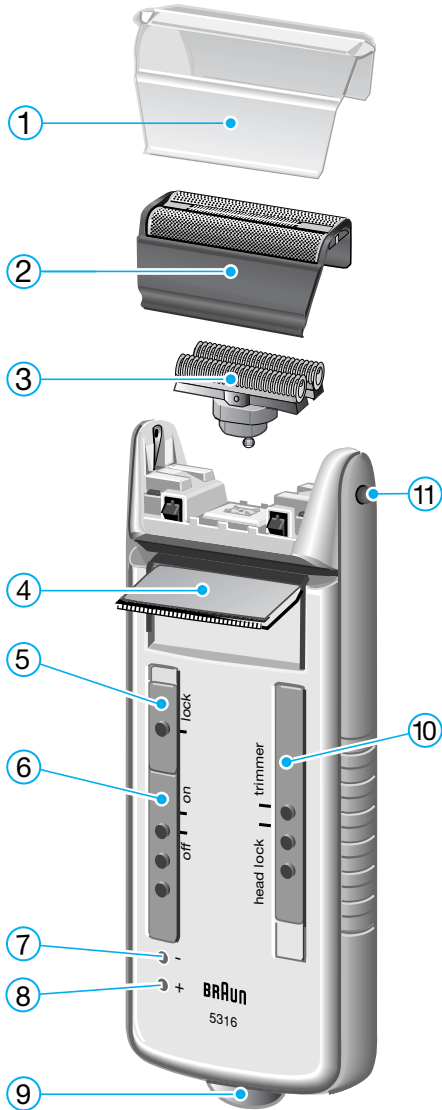

5315

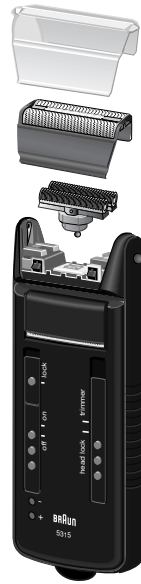

5312 5314



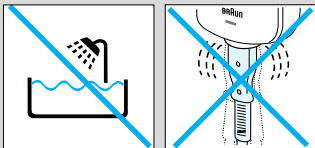

Our products are designed to meet the highest standards of quality, functionality and design. We hope you entirely enjoy your new Braun shaver.

Caution

- Do not use the shaver near, or over, basins filled with water (e. g. bath tubs, showers etc.).
- For safety reasons, periodically check the cord for damage and replace it, if it is loose in the shaver socket.

1 Description

- ① Foil protection cap
- ② Triple shaving frame
- ③ Duo cutter block
- ④ Pop-out long hair trimmer
- ⑤ Switch lock
- ⑥ On/off switch
- ⑦ Low-charge light (red) (models 5316/5315 only)
- ⑧ Charging light (green)
- ⑨ Shaver socket
- ⑩ Switch for locking the swivel head («head lock») and for activating the pop-out long hair trimmer («trimmer»)
- ⑪ Release button

2 Charging the shaver

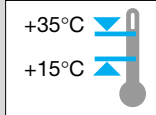
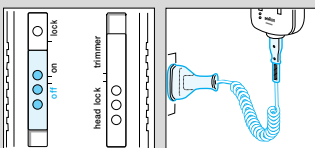

- When charging the shaver for the first time, connect it to the mains and charge it (switch position «off») for at least 4 hours / model 5312: 8 hours. Then shave without the cord until the red low-charge light lights up. (Model 5314/5312: shave without the cord until the shaver runs distinctly slower.)
- Subsequent charges will take approximately 1 hour (5312: 8 hours).
- Wattage: 5 Watts
Voltage range during charging: 12–240 V ≈ / 50 or 60 Hz (automatic adaption)
Best environmental temperature range for charging: 15 °C to 35 °C

3 Pilot lights

- The green charging light indicates that the shaver is connected to the mains. After the cell unit is fully charged, the green charging light goes off. If later on, the charging light comes on again, this indicates that the shaver is being recharged to maintain its full capacity.
- Model 5316/5315 only:
The red low-charge light lights up when the capacity has dropped below 20 %, provided the shaver is switched on. The remaining capacity will then be sufficient for 2 to 3 shaves.

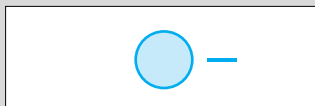

4 Shaving

4.1 Switch lock

The shaver is delivered with the switch lock activated (position «lock»). Push the switch lock up before you shave for the first time. To avoid accidentally switching the shaver on, e. g. when travelling, push the switch lock to position «lock».

4.2 Switch positions

off

on

Shaving with the pivoting head. The pivoting cutting system automatically adjusts to every contour of your face.

head lock

Shaving with the pivoting head locked (to permit shaving in difficult areas, e.g. under the nose)

trimmer

The long hair trimmer is activated (for trimming sideburns, moustache and beard).

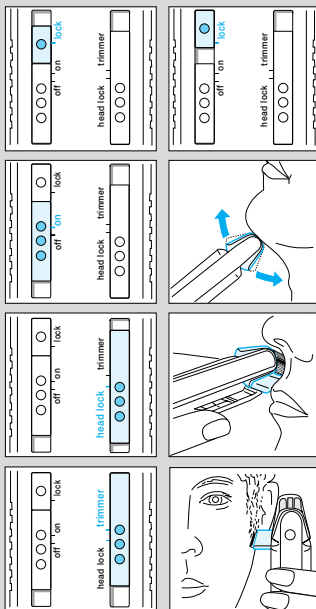

4.3 Shaving with the cord

If the cell unit is discharged, you may also shave with the shaver connected to the mains (100–240 V ~). (If the shaver should not run immediately, charge it with the switch on position «off» for approx. 1 minute.)

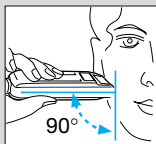

Tips for the perfect shave

- We recommend that you shave before washing, as the skin tends to be slightly swollen after washing.
- Hold the shaver at right angles (90°) to the skin. Stretch your skin and shave against the direction of beard growth.
- To ensure optimum shaving performance, we recommend to replace the shaver foil and cutter block every 18 months, or when the parts are worn.

5 Keeping your shaver in top shape

5.1 Cleaning

- After shaving, switch the shaver off. Press the release button, take off the triple shaving frame and gently tap it out on a flat surface.
- Then thoroughly clean the duo cutter block with the brush as well as the inner area of the pivoting head.
- About every four weeks, clean the duo cutter block with Braun cleaning agents.

5.2 Changing the shaving parts

The shaver foil and cutter block are precision parts that, in time, are subject to wear. Replace your foil frame and cutter block every 18 months and get a 25% better shave.*

(Shaver foil and cutter block: part no. F/C505, available at your dealer or Braun Service Centres)

* (Overall evaluation from Braun users comparing their shave with new parts and those used for 18 months.)

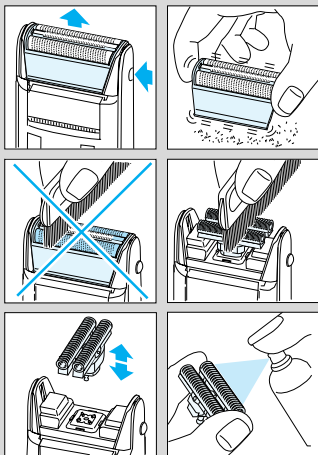

5.3 Preserving the cell unit

- In order to maintain the capacity of the cell unit, the shaver has to be discharged by shaving every 6 months approximately. Then recharge the shaver to full capacity again.
- Do not expose the shaver to temperatures of more than 50 °C for longer periods of time.

6 Accessories

(available from your dealer or at Braun Service centres)

6.1 Wall holder with charge control

6.2 Charging cord as of 12 V

(for boat or car, No. 5-001-687)

Recharging with this cord takes about 20 hours.

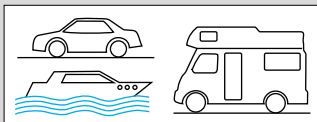
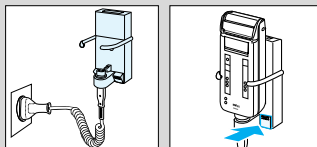

7 Environmental notice

This appliance is provided with a nickel-hydride cell unit. This cell does not contain any harmful heavy metals. Nevertheless, in the interest of recycling raw materials, please do not dispose of this appliance in the household waste at the end of its useful life. Disposal can take place at a Braun Service Centre or appropriate collection sites.

Subject to change without notice.

This product conforms to the EMC-Requirements as laid down by the Council Directive 89/336/EEC and to the Low Voltage Regulation (73/23 EEC).



Deutsch

Garantie

Als Hersteller übernehmen wir für dieses Gerät – nach Wahl des Käufers zusätzlich zu den gesetzlichen Gewährleistungsansprüchen gegen den Verkäufer – eine Garantie von 2 Jahren ab Kaufdatum. Innerhalb dieser Garantiezeit beseitigen wir nach unserer Wahl durch Reparatur oder Austausch des Gerätes unentgeltlich alle Mängel, die auf Material- oder Herstellungsfehlern beruhen. Die Garantie kann in allen Ländern in Anspruch genommen werden, in denen dieses Braun Gerät von uns autorisiert verkauft wird.

Von der Garantie sind ausgenommen: Schäden durch unsachgemäßen Gebrauch, normaler Verschleiß und Verbrauch sowie Mängel, die den Wert oder die Gebrauchstauglichkeit des Gerätes nur unerheblich beeinflussen. Bei Eingriffen durch nicht von uns autorisierte Braun Kundendienstpartner sowie bei Verwendung anderer als Original Braun Ersatzteile erlischt die Garantie.

Im Garantiefall senden Sie das Gerät mit Kaufbeleg bitte an einen autorisierten Braun Kundendienstpartner. Die Anschrift für Deutschland können Sie kostenlos unter 00800/27 28 64 63 erfragen.

English

Guarantee

We grant 2 years guarantee on the product commencing on the date of purchase. Within the guarantee period we will eliminate, free of charge, any defects in the appliance resulting from faults in materials or workmanship, either by repairing or replacing the complete appliance as we may choose.

This guarantee extends to every country where this appliance is supplied by Braun or its appointed distributor.

This guarantee does not cover: damage due to improper use, normal wear or use as well as defects that have a negligible effect on the value or operation of the appliance. The guarantee becomes void if repairs are undertaken by unauthorised persons and if original Braun parts are not used.

To obtain service within the guarantee period, hand in or send the complete appliance with your sales receipt to an authorised Braun Customer Service Centre.

For UK only:

This guarantee in no way affects your rights under statutory law.

Français

Garantie

Nous accordons une garantie de 2 ans sur ce produit, à partir de la date d'achat. Pendant la durée de la garantie, Braun prendra gratuitement à sa charge la réparation des vices de fabrication ou de matière en se réservant le droit de décider si certaines pièces doivent être réparées ou si l'appareil lui-même doit être échangé. Cette garantie s'étend à tous les pays où cet appareil est commercialisé par Braun ou son distributeur exclusif.

Cette garantie ne couvre pas : les dommages occasionnés par une utilisation inadéquate et l'usure normale. Cette garantie devient caduque si des réparations ont été effectuées par des personnes non agréées par Braun et si des pièces de rechange ne provenant pas de Braun ont été utilisées.

Pour toute réclamation intervenant pendant la période de garantie, retournez ou rapportez l'appareil ainsi que l'attestation de garantie à votre revendeur ou à un Centre Service Agréé Braun.

Appelez au 01.47.48.70.00 pour connaître le Centre Service Agréé Braun le plus proche de chez vous.

Clause spéciale pour la France

Outre la garantie contractuelle exposée ci-dessus, nos clients bénéficient de la garantie légale des vices cachés prévue aux articles 1641 et suivants du Code civil.